



EA211 | EA288 | EA888

VW | Audi | Seat | Skoda | MAN



Das Original



EA211

4 1.4 l TSI

EA288

10 1.6 l + 2.0 l TDI

18 2.0 l TDI

EA888

24



26 Gen. I + II | 1.8 l + 2.0 l TSI

36 Gen. III | 2.0 l TSI

42 Gen. IV | 2.0 l TSI

54



Online sealant adviser: Find the right product in 3 steps

Elring-Dichtmassenberater: In 3 Schritten zu Ihrem Produkt

Conseiller en pâtes à joint Elring: Trouvez le bon produit en 3 étapes

Asesor de pastas sellantes de Elring: Su producto ideal a tan solo 3 pasos













Il consulente sui sigillanti di Elring: In 3 passi al prodotto giusto

Asystent w doborze mas uszczelniających Elring. Znajdź właściwy produkt w 3 krokach



EA211 1.4 | TSI

Top Mover

	#		
	352.421	-	Audi: A3 Q3 Seat: Alhambra Leon Tarraco Toledo Skoda: Fabia Kodiaq Octavia Rapid Superb Yeti VW: Beetle Caddy CC Golf Jetta Passat Polo Scirocco Tiguan Touran
	446.900	-	Audi: A4 A5
	774.960	-	Audi: A1 A3 Q2 Seat: Ateca Ibiza Leon Skoda: Karoq Kodiaq Superb VW: Golf Passat Polo Tiguan
	774.910	-	Audi: A3 VW: Jetta Vento Bora
	529.070	-	Seat: Alhambra Ateca VW: Caddy Sharan
	523.430	-	Audi: A1 A3 A4 Q2 Q3 Seat: Alhambra Arona Ateca Ibiza Leon Tarraco Toledo Skoda: Fabia Kamiq Karoq Kodiaq Octavia Rapid Scala Superb Yeti VW: Beetle Caddy CC Golf Jetta Passat Polo Scirocco Sharan Taos T-Cross Tiguan Touran T-Roc Virtus Sagitar Grand Lavida Lavida
	721.972	04E 103 383 AM	Audi: A1 A3 Q2 Q3 Seat: Alhambra Ateca Leon Tarraco Toledo Skoda: Fabia Kodiaq Octavia Rapid Superb Yeti VW: Beetle Caddy CC Golf Jetta Passat Polo Scirocco Tiguan Touran
	898.272	04E 103 383 BL	Audi: A3
	311.040	04E 103 383 CA	Audi: A4 A5
	445.910	WHT 007 089	Audi: A1 A3 A4 A5 Q2 Q3 Seat: Alhambra Arona Ateca Ibiza Leon Tarraco Toledo Skoda: Fabia Kamiq Karoq Kodiaq Octavia Rapid Scala Superb Yeti VW: Arteon Beetle Caddy CC Fox Golf Jetta Multivan T7 Passat Polo Saveiro Scirocco Sharan Spacefox Taigo Taigun Taos T-Cross Tiguan Touran T-Roc Virtus Voyage Bora Cross Lavida Grand Lavida Gran Santana C-Trek Lamando Lavida Magotan Sagitar Santana Tacqua Tayron

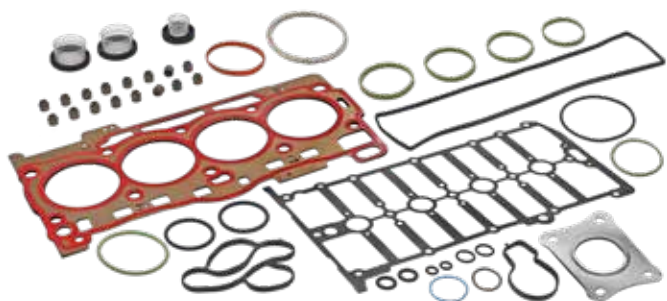

529.070



523.430

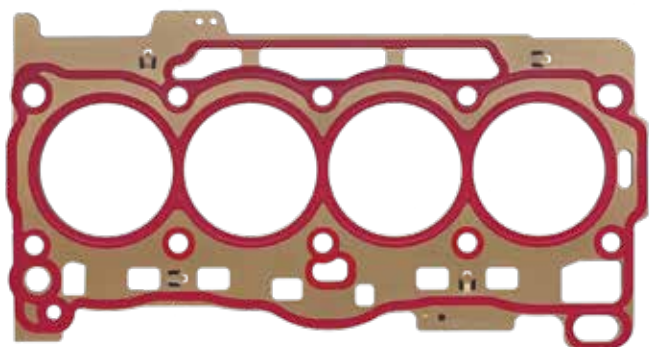

311.040 // OE # 04E 103 383 CA
Ø 75,5 mm | $\frac{+}{-}$ 0,72 mm

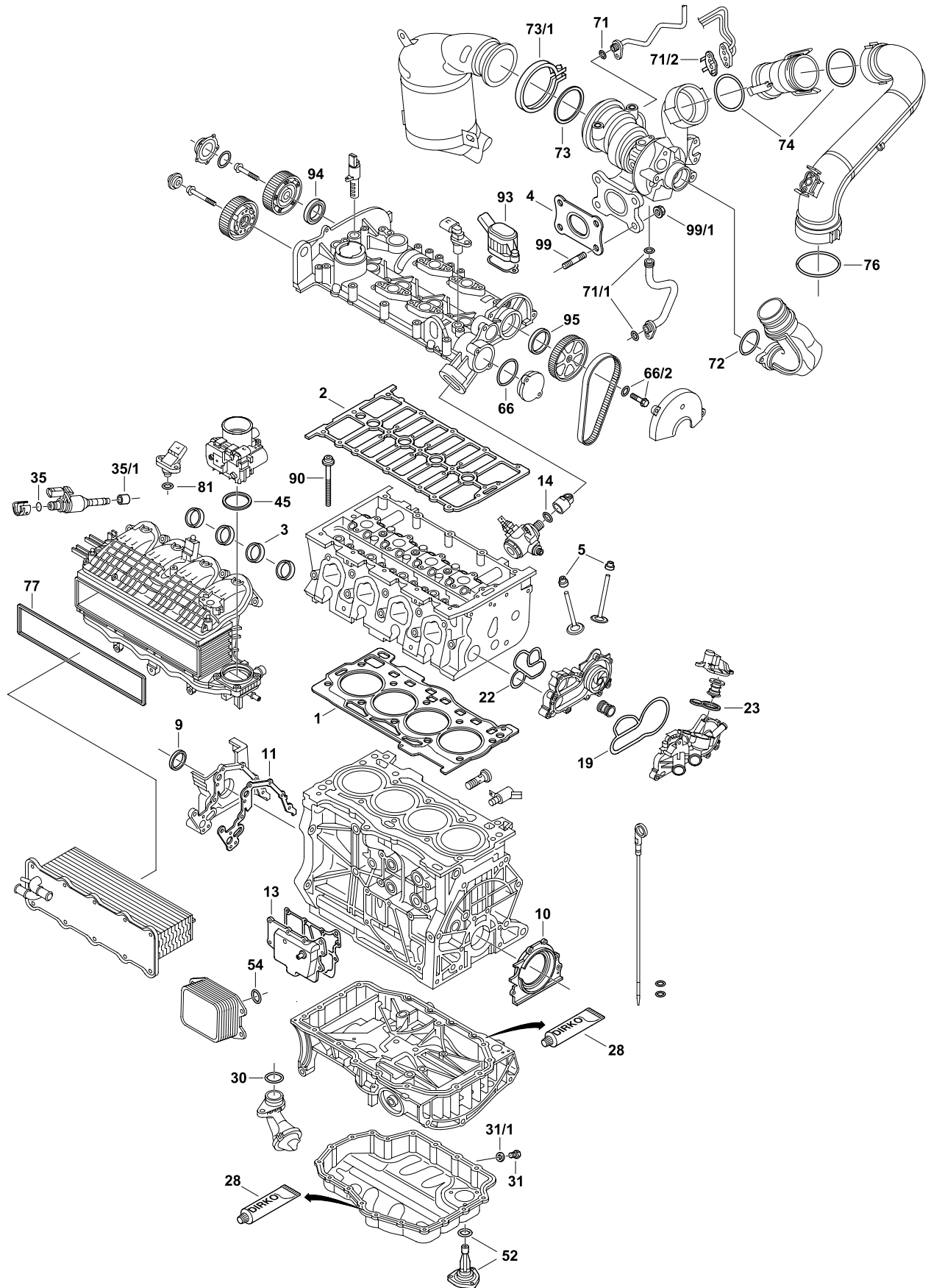



	352.421	1	-	$\pm 1,02$ mm	1.4 TSI
	774.960	1	-	$\pm 1,02$ mm	1.4 TSI ACT
	774.910	1	-	$\pm 1,02$ mm	1.4 TSI Hybrid USA
	529.070	1	-	$\pm 0,8$ mm	1.4 TSI OPF
	446.900	1	-	$\pm 0,8$ mm	1.4 TSI
	523.430	1	-	-	-
	445.910	1	WHT 007 089 (10x)	M9x1.25x140 12.9	
	595.180	1	04E 145 701 B	-	-
	446.150	4	06M 998 907	-	-
	113.880	4	04E 906 907 E	-	1.4 TSI E-Tron
1	721.972	1	04E 103 383 AM	$\varnothing 75,5$ mm $\pm 1,02$ mm	-
1	898.272	1	04E 103 383 BL	$\varnothing 75,5$ mm $\pm 1,02$ mm	1.4 TSI Hybrid USA
1	311.040	1	04E 103 383 CA	$\varnothing 75,5$ mm $\pm 0,72$ mm	1.4 TSI Audi A4
2	898.042	1	04E 103 483 H	-	-
2	633.710	1	04E 103 483 AE	-	for OE No. 04E103469DS, 04E103469ED, 04E103469ER
3	470.370	4	036 129 717 E	45 x 49,6 x 5 FPM	-
4	223.440	1	04E 253 039 E	-	-
5	302.890	16	04E 109 675	5x7,8/11,2x9,7 FPM	-
5	308.610	8	04E 109 675 A	5x7,8/11x10,3 FPM	1.4 TSI Hybrid USA
9	248.270	1	04C 103 085 B	30x40x7 RD \rightarrow ASW PTFE/AEM	-
10	523.120	1	04E 103 170 Q	$\varnothing 85$ mm IWDR LD \leftarrow PTFE	-
11	092.360	1	04E 103 161	-	-
11	245.730	1	04C 103 161 D 04C 103 161 F	-	-
13	928.240	1	04E 103 517 E	AEM	-
14	174.270	1	06E 127 248	O-Ring 31x2 FPM	-
14	430.030	1	WHT 008 259	O-Ring 31,5x1,8 FPM	-
19	323.380	1	04E 121 119 C	-	-
22	249.150	1	04C 121 119	-	-
23	938.850	1	04E 121 119 D	-	-
28	036.164	1	-	-	Dirko™ HT
30	733.490	1	N 028 222 2	O-Ring 20x3,15 FPM	-

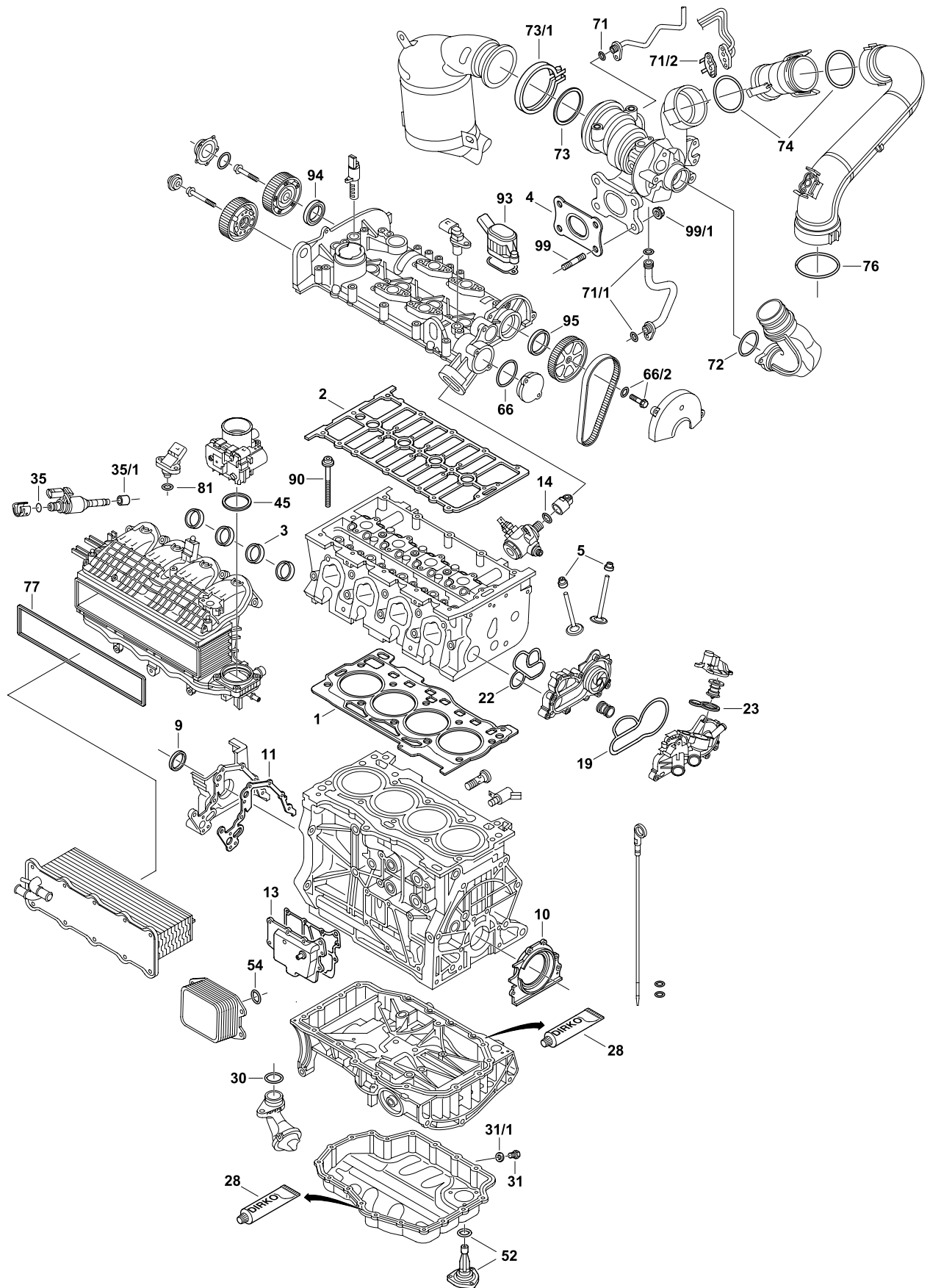

















31	589.640	1	N 902 889 01	M14 x 1,5 x 16	
31/1	591.840	1	N 013 815 7 N 013 815 8	14x20x2 DIN 7603 C	
35	904.050	4	-	O-Ring 5,94x3,53 FPM	-
35/1	456.900	4	-	6,1x7,8x3,4 PTFE	-
45	725.200	1	03C 133 073 A	65,3x69,5x5,5 FPM A	-
52	351.210	1	038 103 196 B	AEM	-
54	315.540	4	04E 115 111 D	-	-
66	915.556	1	N 903 445 01	O-Ring 45x3 FPM	-
66/2		1	WHT 007 568	O-Ring 69,4x3,1 ACM	-
66/2		1	N 908 514 01	O-Ring 14x1,8 FPM	-
71	355.940	2	WHT 006 990 A	O-Ring 7,59x2,62 FPM	-
71/1	224.450	2	WHT 005 363 WHT 005 363 A	O-Ring 12,4x3,53 FPM	-
71/2	548.691	1	04E 121 687	Metaloseal™	-
72	268.402	1	WHT 001 386	O-Ring 44x4 FPM	-
73	741.490	1	5C0 253 115 A 5QD 253 115 B	-	-
73/1	100.230	1	5Q0 253 725 H	-	-
74	268.402	2	WHT 001 386	O-Ring 44x4 FPM	-
76	847.040	1	WHT 003 247	O-Ring 65x4 FPM	-
77	341.310	1	04E 129 717 C	-	-
81		1	036 906 149 D	O-Ring 7,59 x 2,62	-
90	445.910	10	WHT 007 089	M9 x 1,25 x 140 12.9	
93	238.350	4	N 910 200 01	O-Ring 17,3x1,5 FPM	-
94	242.650	2	04E 103 085 AF	36x46x7 RD → ASW PTFE/ACM	-
95	242.620	1	04E 103 085	24x39x8 LD ← ASW PTFE/ACM	-
99	584.580	4	N 901 889 02	M8x35	-
99/1	356.120	4	WHT 000 001 N	M8x1,25x15,7	

EA288

1.6 | + 2.0 | TDI

Top Mover

	#		
	496.060	-	Audi: A1 Seat: Toledo Skoda: Rapid Superb VW: Passat
	496.070	-	Audi: A3 Q2 VW: Golf Polo
	576.280	-	Audi: A3 Q2 Q3 Seat: Alhambra Ateca Leon Tarraco Skoda: Karoq Kodiaq Octavia Superb Yeti VW: Arteon Beetle Caddy CC Golf Jetta Passat Scirocco Sharan Tiguan Touran T-Roc
	391.000	-	Audi: A3 Q2 Seat: Ateca Leon Skoda: Karoq Kodiaq Octavia Superb VW: Arteon Caddy Golf Passat Tiguan Touran
	784.530	-	Audi: A3 Q2 Q3 TT Seat: Alhambra Ateca Leon Tarraco Skoda: Karoq Kodiaq Octavia Superb VW: Arteon CC Golf Passat Scirocco Sharan Tiguan Touran T-Roc
	452.990	-	Audi: A1 A3 A4 A5 A6 Q2 Q3 Q5 TT Seat: Alhambra Arona Ateca Ibiza Leon Tarraco Toledo Skoda: Kamiq Karoq Kodiaq Octavia Rapid Scala Superb Yeti VW: Arteon Beetle Caddy California T6 CC Crafter Golf Grand California Jetta Multivan T6 Passat Passat Alltrack Polo Scirocco Sharan T-Cross Tiguan Touran Transporter T6 T-Roc MAN: TGE
	718.051	04L 103 383 C	Audi: A1 A3 Q2 Seat: Arona Ibiza Leon Toledo Skoda: Kamiq Karoq Octavia Rapid Scala Superb VW: Golf Passat Polo T-Cross Tiguan Touran T-Roc
	718.061	04L 103 383 D	Audi: A1 A3 Q2 Seat: Arona Ibiza Leon Toledo Skoda: Kamiq Karoq Octavia Rapid Scala Superb VW: Golf Passat Polo T-Cross Tiguan Touran T-Roc
	718.071	04L 103 383 E	Audi: A1 A3 Q2 Seat: Arona Ibiza Leon Toledo Skoda: Kamiq Karoq Octavia Rapid Scala Superb VW: Golf Passat Polo T-Cross Tiguan Touran T-Roc
	593.930	04L 103 383 BJ	Audi: A3 A4 A5 A6 Q2 Q3 Q5 TT Seat: Alhambra Ateca Leon Tarraco Skoda: Karoq Kodiaq Octavia Superb Yeti VW: Arteon Beetle Caddy CC Golf Jetta Passat Scirocco Sharan Tiguan Touran T-Roc
	593.940	04L 103 383 BK	Audi: A3 A4 A5 A6 Q2 Q3 Q5 TT Seat: Alhambra Ateca Leon Tarraco Skoda: Karoq Kodiaq Octavia Superb Yeti VW: Arteon Beetle Caddy CC Golf Jetta Passat Scirocco Sharan Tiguan Touran T-Roc
	593.950	04L 103 383 BL	Audi: A3 A4 A5 A6 Q2 Q3 Q5 TT Seat: Alhambra Ateca Leon Tarraco Skoda: Karoq Kodiaq Octavia Superb Yeti VW: Arteon Beetle Caddy CC Golf Jetta Passat Scirocco Sharan Tiguan Touran T-Roc
	351.900	WHT 005 673	Audi: A1 A3 A4 A5 A6 Q2 Q3 Q5 TT Seat: Alhambra Arona Ateca Ibiza Leon Tarraco Toledo Skoda: Kamiq Karoq Kodiaq Octavia Rapid Scala Superb Yeti VW: Arteon Beetle Caddy CC Golf Jetta Passat Scirocco Sharan Tiguan Touran T-Roc

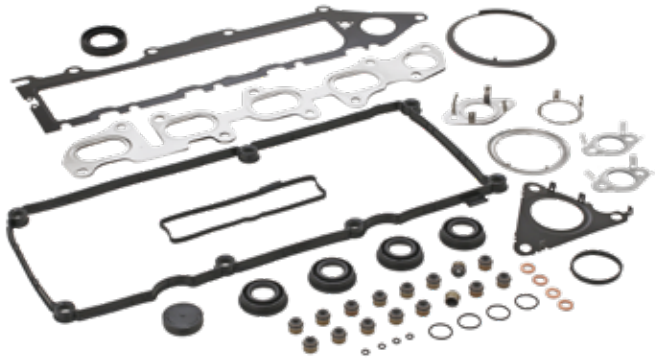

576.280

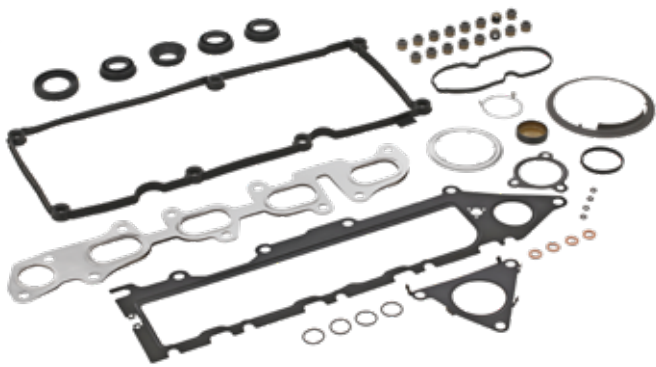

784.530

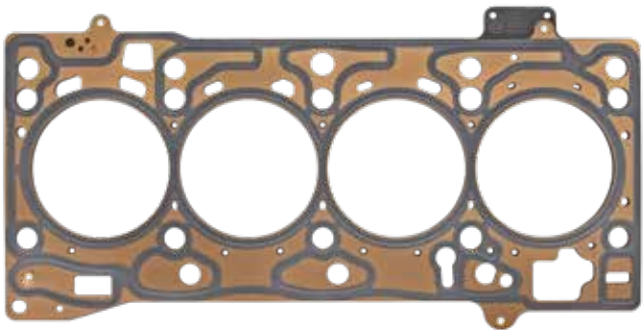

593.930 // OE # 04L 103 383 BJ
Ø 82,3mm | $\frac{1}{16}$ 1,55

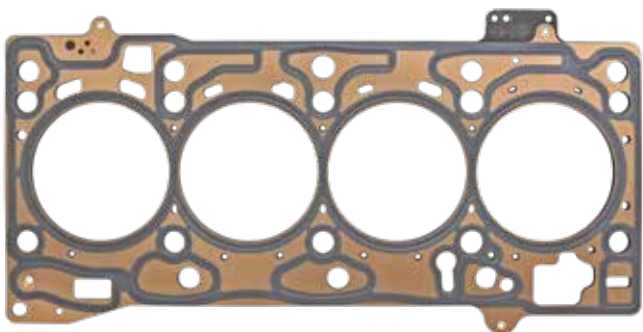

593.940 // OE # 04L 103 383 BK
Ø 82,3mm | $\frac{1}{16}$ 1,63

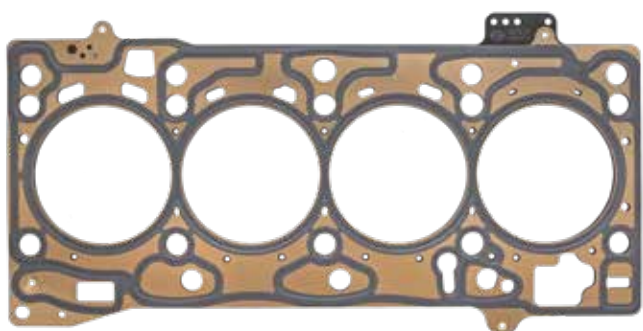

593.950 // OE # 04L 103 383 BL
Ø 82,3mm | $\frac{1}{16}$ 1,71

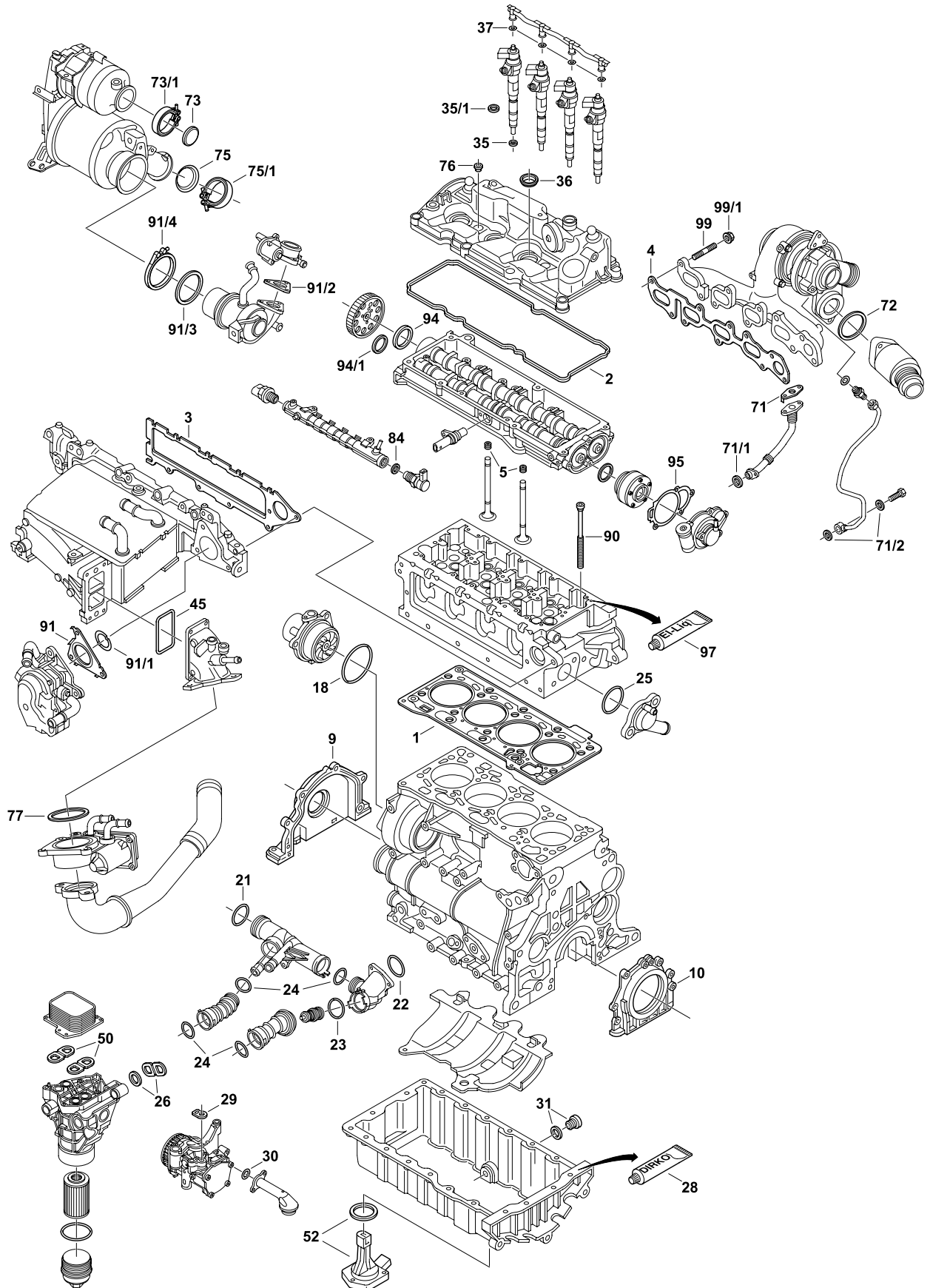



	496.060	-	-	-	for 1.6 l TDI: DCX* / DCZ*
	496.070	-	-	-	for 1.6 l TDI: DGT* / DDY*
	576.280	-	-	-	-
	391.000	-	-	-	-
	784.530	-	-	-	-
	452.990	-	-	-	-
	351.900	-	WHT 005 673 (10x)	-	
	235.610	-	-	-	-
	982.100	-	-	-	for OE No. 04L103469
	982.110	-	-	-	for OE No. 03L103469S, 03L103469T, 03L103475T, 03L103475S, 03L103469AD
	570.870	-	-	-	for OE No. 04L253010B, 04L253010T, 04L253016F, 04L253016H, 04L253016K, 04L253019P, 04L253019Q, 04L253020H
	695.560	-	-	-	Audi A4 Audi A5 Audi A6 Audi Q5 for OE No. 04L253019A, 04L253020N
	388.780	-	-	-	for OE No. 04L253010J, 04L253010K, 04L253019R
	482.140	-	03N 198 070	-	-
	883.700	-	-	-	Bosch
	883.670	-	-	-	Siemens
1	718.051	1	04L 103 383 C	Ø 80,5mm $\frac{\text{H7}}{k6}$ 1,55	Num. of holes: 1
1	718.061	1	04L 103 383 D	Ø 80,5mm $\frac{\text{H7}}{k6}$ 1,63	Num. of holes: 2
1	718.071	1	04L 103 383 E	Ø 80,5mm $\frac{\text{H7}}{k6}$ 1,71	Num. of holes: 3
1	593.930	1	04L 103 383 BJ	Ø 82,3mm $\frac{\text{H7}}{k6}$ 1,55	Num. of holes: 1
1	593.940	1	04L 103 383 BK	Ø 82,3mm $\frac{\text{H7}}{k6}$ 1,63	Num. of holes: 2
1	593.950	1	04L 103 383 BL	Ø 82,3mm $\frac{\text{H7}}{k6}$ 1,71	Num. of holes: 3
2	374.000	1	04L 103 483	-	for OE No. 04L103469, 04L103469A, 04L103469D, 04L103469P, 04L103469Q, 04L103469S, 04L103475, 04L103475A, 04L103475D

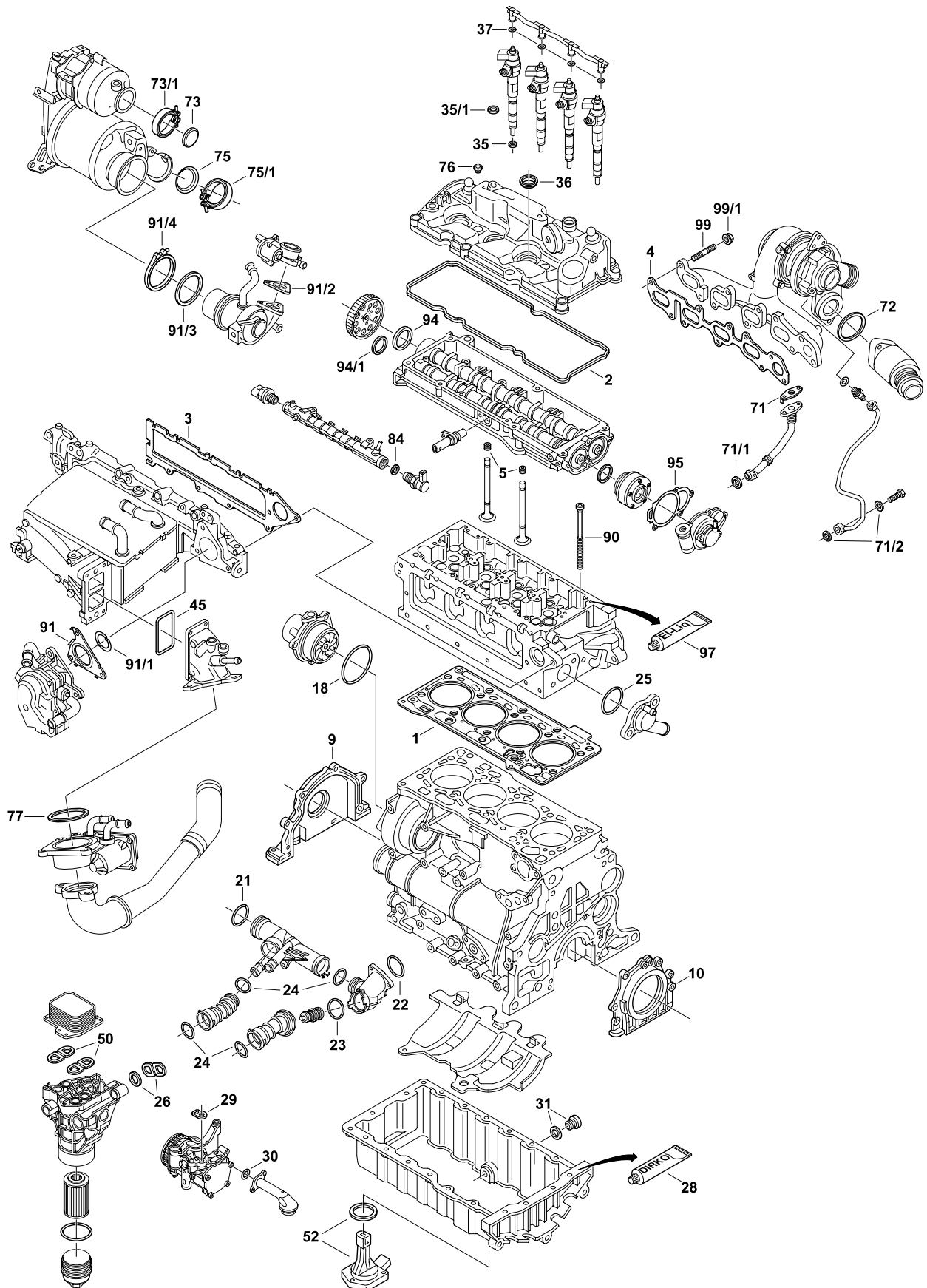



2	330.200	1	03L 103 483 S	-	for OE No. 03L103469AC, 03L103469AE, 03L103469S, 03L103469T, 03L103475AC, 03L103475S, 03L103475T
3	352.810	1	04L 129 717 D	-	-
3	796.400	1	04L 129 717 F	-	-
4	902.561	1	04L 253 039 G	-	-
4	729.571	1	04L 253 039 B	-	-
4	328.170	1	04L 253 039 D	-	-
5	724.590	16	036 109 675 A	-	-
9	340.290	1	04L 103 151 A	Ø 35mm SP RD → PTFE	-
10	340.280	1	04L 103 171	Ø 85mm IWD LD ← PTFE	-
18	332.850	1	04L 121 119 F	-	-
21	703.570	1	04L 121 119	-	-
22	332.720	1	04L 121 119 B	-	-
23		1	-	-	-
24	328.210	4	N 907 653 01	O-Ring 32x4 EPDM-PX	-
25	332.740	1	04L 121 688	-	-
26		1	03N 115 441	-	-
28	030.793	1	-	-	Dirko™ HT
29	332.970	1	04L 145 625	-	-
30	733.490	1	N 028 222 2	O-Ring 20x3 FPM	-
31	567.640	1	N 908 132 02	-	with seal ring mit Dichtring avec bague d'étanchéité con junta tórica con anello tenuta z pierścieniem uszczelniającym
35	173.190	4	059 130 519	7,2/7,7x13x1,5 CU A	Bosch
35	426.780	4	03L 130 519	7/7,7x12,3x2,46 CU A	Siemens
35/1	219.950	4	WHT 000 884	O-Ring 16,2x1,5 FPM	-
36	811.540	4	04L 103 070 A	-	for OE No. 04L103469, 04L103469B, 04L103469E, 04L103469J
36	380.150	4	04L 103 070	-	for OE No. 03L103469S, 03L103469T, 03L103475T, 03L103475S, 03L103469AD
37	344.860	4	WHT 006 492	O-Ring 3,3x1,55 FPM	Siemens
37	351.880	4	WHT 005 301	O-Ring 3,3x1,4 FPM	Siemens
37	330.020	4	WHT 006 497	O-Ring 3,52x1,4 FPM	Bosch
45	467.780	1	04L 131 547 N	-	-
50		3	03N 117 070	-	-
52	351.210	1	038 103 196 B	-	-
71	245.830	1	04B 145 757	-	-

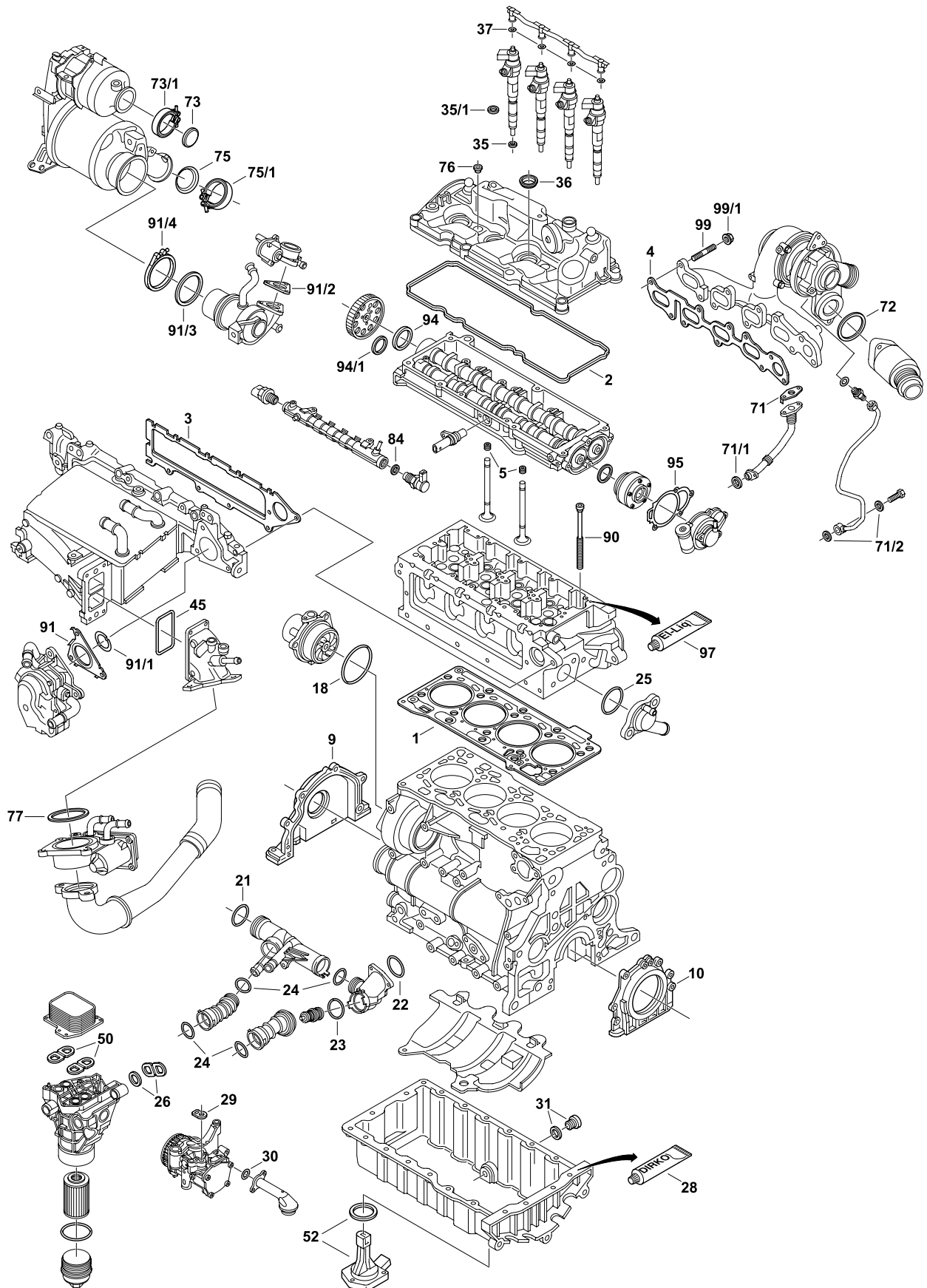



71/1	452.290	1	WHT 007 702	O-Ring 17,13x2,62 VMQ	-
71/2	068.616	2	N 013 813 3	12x17x1,5 Al A	-
72	693.650	1	04L 145 117 C	O-Ring 35x3,55 FPM	-
72	487.450	1	04L 145 117 B	O-Ring 49x3 FPM	-
72	006.060	1	04L 145 117	O-Ring 56x3 FPM	-
72	651.000	1	04B 145 117	O-Ring 62x3 FPM	-
73	472.550	1	04L 253 115 A	-	-
73/1	259.900	1	04L 253 725 B	-	-
75	494.560	1	1K0 253 115 AE	-	-
75	534.780	1	4G0 253 115 H	-	-
75/1	259.900	1	1K0 253 725	-	-
76	035.450	2	04L 103 631 A	-	-
77	467.820	1	04L 131 547 J	-	-
77	479.050	1	04L 131 547 R	-	for OE No. 04L128063AA
84		1	WHT 004 740 A	-	-
90	351.900	10	WHT 005 673	M12x1,75x206 10.9	
91	323.320	1	04L 131 547 L	Metaloseal™	-
91	767.310	1	04L 131 547 P	Metaloseal™	for OE No. 04L131501R, 04L131501AD
91/1	330.560	1	04L 131 547 M	Metaloseal™	-
91/1	767.290	1	04L 131 547 Q	Metaloseal™	for OE No. 04L131501R, 04L131501AD
91/2	727.770	1	04L 131 547 A	-	-
91/3	722.390	1	04L 131 547	-	-
91/3	005.250	1	04L 131 547 G	-	for OE No. 04L131513B
91/4	484.970	1	04L 131 455 A	-	-
94	897.690	1	03L 103 085 C	32x47x10 RD → PTFE/ACM	-
94/1	391.020	1	03L 103 113 A	32x8,5 FE/ACM	-
95	773.720	1	03L 145 215 F	Metaloseal™	for OE No. 03L109096
95	798.300	1	03L 145 215 J	Metaloseal™	for OE No. 03L109096B
95	732.692	1	04L 145 215	Metaloseal™	for OE No. 04L109096
95	332.730	1	04L 145 215 C	Elastomer	for OE No. 04L109283C
97	461.682	1	-	-	
99	584.580	10	N 901 889 02	M8x35	-
99/1	247.130	10	N 904 539 01	M8	-

EA288 2.0 | TDI

Top Mover



	798.740	-	VW: California T6 Camper Crafter Grand California Multivan T6 Transporter T6 MAN: TGE
	452.990	-	VW: Caddy California T6 Camper Crafter Grand California Multivan T6 Transporter T6 MAN: TGE
	298.091	04L 103 383 AM	VW: California T6 Camper Crafter Grand California Multivan T6 Transporter T6 MAN: TGE
	298.101	04L 103 383 AN	VW: California T6 Camper Crafter Grand California Multivan T6 Transporter T6 MAN: TGE
	298.111	04L 103 383 AP	VW: California T6 Camper Crafter Grand California Multivan T6 Transporter T6 MAN: TGE
	864.450	WHT 007 433 65.90030-0037	VW: Caddy V Caddy California V Camper California Crafter Grand California Multivan T6 Transporter T6 MAN: TGE



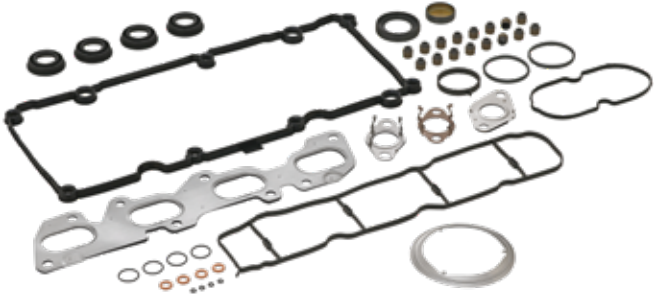

452.990



798.740

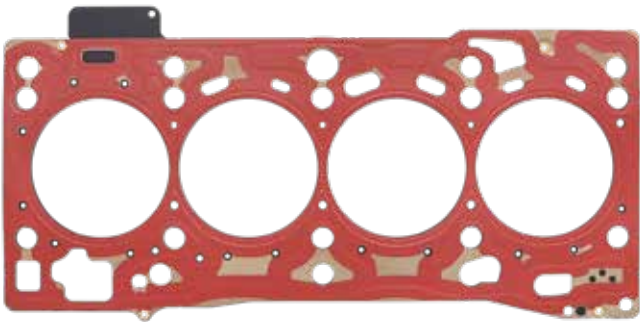

298.091 // VW OE # 04L 103 383 AM
// MAN OE # 65.03901-0000
Ø 82,3mm | \pm 1,55

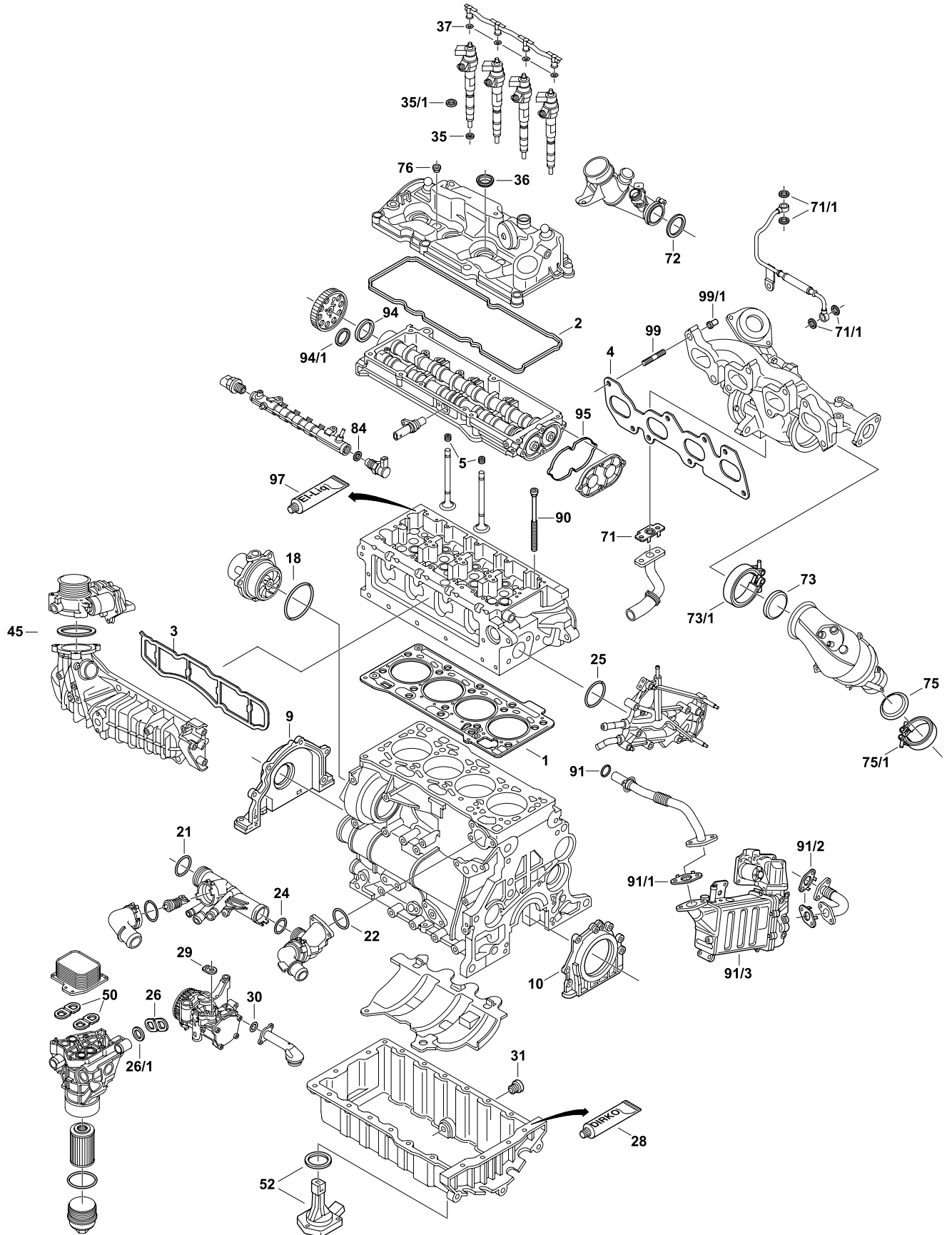



	798.740	1	-	-	-	-
	452.990	1	-	-	-	-
	864.450	1	WHT 007 433 (10x)	65.90030-0037 (10x)	-	
	795.420	1	-	-	-	for OE No. 04L253014C, 04L253014F, 04L253016S
	877.670	1	-	-	-	for OE No. 03N145703K, 03N145703M, 03N145703N, 03N145703R, 03N145703T, 03N145704, 1635970-0018, 1635988-0018, 65.09100-6000, 65.09100-6002, 65.09100-6005, 65.09100-6006
	933.920	1	03N 198 052 C	65.09904-6000	-	Bi-Turbo
	934.010	1	03N 198 052 E	65.08901-6001	-	Bi-Turbo
	982.090	1	-	-	-	for OE No. 04L103469B, 04L103469E, 04L103469J
	482.140	1	03N 198 070	-	-	-
	090.700	4	-	-	-	-
1	298.091	1	04L 103 383 AM	65.03901-0000	Ø 82,3mm 1,55	Num. of holes: 1
1	298.101	1	04L 103 383 AN	65.03901-0001	Ø 82,3mm 1,63	Num. of holes: 2
1	298.111	1	04L 103 383 AP	65.03901-0002	Ø 82,3mm 1,71	Num. of holes: 3
2	589.570	1	04L 103 483 A	65.03905-0000	-	for OE No. 04L103469B, 04L103469E, 04L103469J, 04L103469M
3	798.070	1	04L 129 717 E	65.08902-0002	-	-
3	147.240	1	04L 129 717 J	65.08902-0007	-	for OE No. 04L129709N, 65.08201-6012, 65.08201-6014
4	793.130	1	04L 253 039 H	65.08901-0000	-	-
5	308.610	16	04E 109 675 A	65.04902-0001	5x7,8/11x10,3 FPM	-
9	340.290	1	04L 103 151 A	65.01503-0002	-	-
10	340.280	1	04L 103 171	65.01503-0001	-	-
18	332.850	1	04L 121 119 F	65.96503-0000	-	-
21	703.570	1	04L 121 119	65.96503-0001	-	-
22	332.720	2	04L 121 119 B	65.96503-0002	-	-
24	328.210	1	N 907 653 01	65.96501-0036	O-Ring 32x4 EPDM-PX	-
25	332.720	1	04L 121 119 B	65.96503-0002	-	-
26		1	03N 117 070	65.05901-0000	-	-
26/1		1	03N 115 441	65.05901-0001	-	-

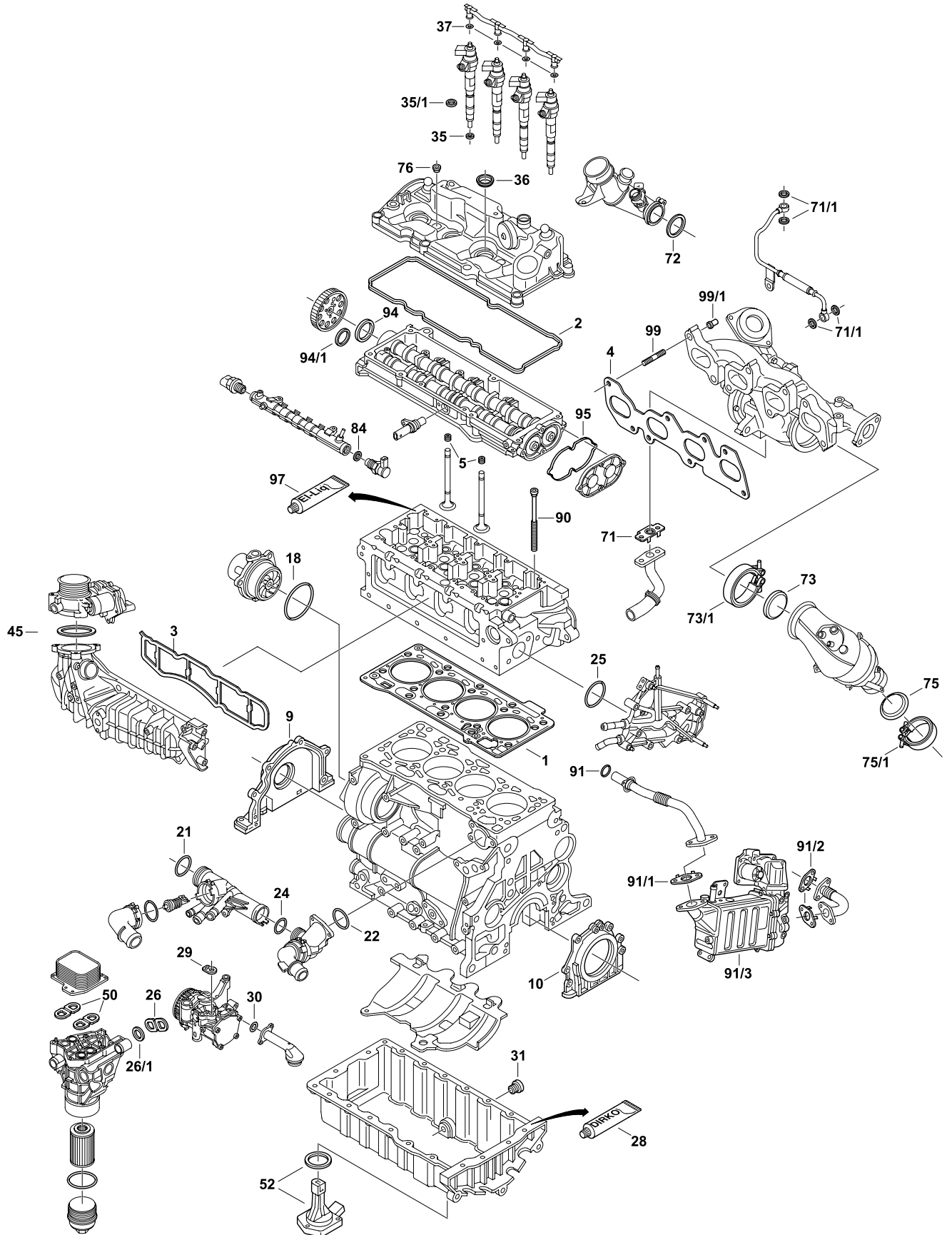



28	030.793	1	-	-	-	 Dirko™ HT 
29	332.970	1	04L 145 625	65.05907-0000	-	-
30	733.490	1	N 028 222 2	65.96501-0015	O-Ring 20x3 FPM	-
31	567.640	1	N 908 132 02	65.90310-0000	-	with seal ring mit Dichtring avec bague d'étanchéité con junta tórica con anello tenuta z pierścieniem uszczelniającym
35	797.960	4	04L 130 519 B	65.98701-0000	7,1x12,3x1,5 CU A	-
35/1	219.950	4	WHT 000 884	65.96501-0004	O-Ring 16,2x1,5 FPM	-
36	380.150	4	04L 103 070 B	65.03903-0000	-	-
37	455.830	4	WHT 007 480 A	65.96501-0033	O-Ring 2,8x1,5 FPM	-
45		1	04L 145 113	65.08902-0003	-	-
50		2	-	-	-	-
52	351.210	1	038 103 196 B	-	-	-
71	795.400	1	04L 145 757 B	65.05903-0003	-	-
71	549.180	2	03L 145 757 F	65.05903-0001	-	Bi-Turbo
71/1	068.616	4	N 013 813 3	65.96601-0001	12x17x1,5 Al A	-
72		1	7E0 129 496	-	-	-
73	352.550	1	2H0 253 115	65.15901-0000	-	-
73/1	566.570	1	2H0 253 725	65.97420-0000	Ø 86 mm	-
75	510.470	1	7E0 253 115 J	65.15901-0001	-	-
75/1	566.570	1	2H0 253 725	65.97420-0000	Ø 86 mm	-
76	147.230	2	04B 103 631	65.96001-0001	-	-
84		1	WHT 008 239	65.96501-0058	O-Ring 21,2x1,9 FPM	-
90	864.450	10	WHT 007 433 (10x)	65.90030-0037 (10x)	M12x1,75x209 12.9	
91	784.710	1	04L 131 120	65.08902-0004	-	-
91/1	429.050	1	03L 131 547 D	65.08901-0001	-	-
91/2	728.870	2	03L 131 547 P	65.08901-0002	-	-
91/3	060.700	1	-	-	Metaloseal™	-
94	897.690	1	03L 103 085 C	65.04901-0001	32x47x10 RD → PTFE/ACM	-
94/1	391.020	1	03L 103 113 A	65.04408-0000	32x8,5 FE/ACM	-
95	332.730	1	04L 145 215 C	65.04901-0000	-	-
97	461.682	1	-	-	-	
99	584.580	8	N 901 889 02	65.90210-0003	M8x35	-
99	685.700	8	N 044 407 6	65.90210-0004	M8x1,25x50	Bi-Turbo
99/1	305.600	8	WHT 003 842	65.90501-0001	M8x1,25x22	-
99/1	365.930	8	WHT 005 430	65.90640-0000	M8x1,25x36	Bi-Turbo

EA888

685.662 // OE # 06H 103 383 AA // OE # 06H 103 383 AC
// OE # 06H 103 383 AD // OE # 06H 103 383 AF

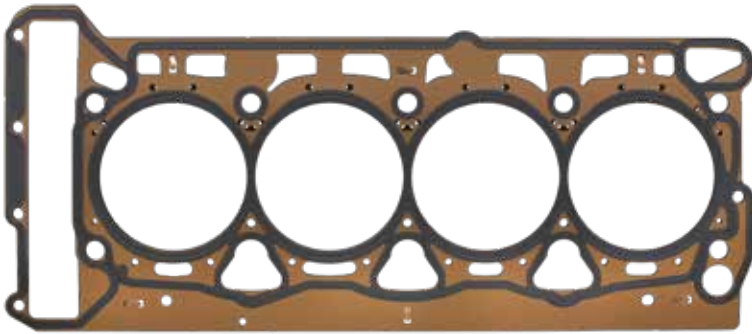

Generation I/II
Ø 83,3mm | $\pm 0,9$ mm

008.040 // OE # 06L 103 383 B // OE # 06K 103 383 K
// OE # 958 103 383 10

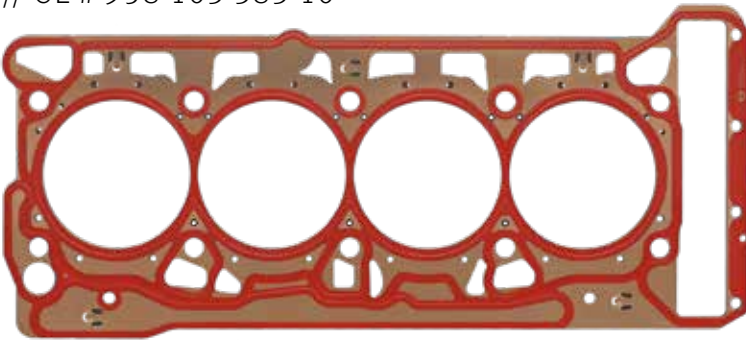

Generation III
Ø 83,3mm | $\pm 0,9$ mm

564.640 // OE # 06N 103 383 B // OE # 06J 103 383 AD
// OE # 06L 103 383 C

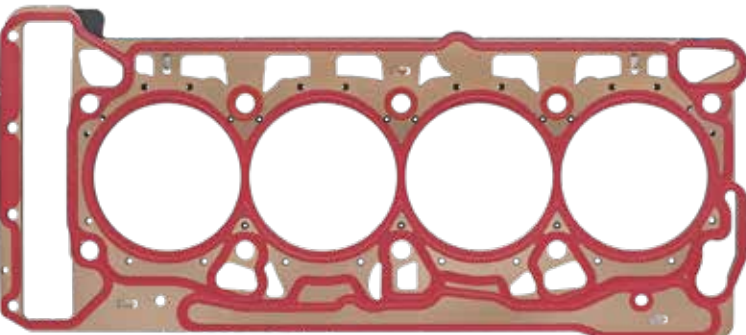

Generation IV
Ø 83,3mm | $\pm 0,9$ mm

564.670 // OE # 06Q 103 383 A

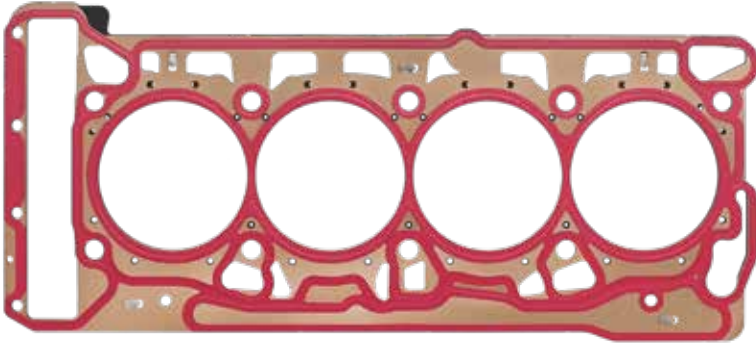

Generation IV
Ø 83,3mm | $\pm 0,9$ mm

893.170 // OE # 06Q 103 383 A

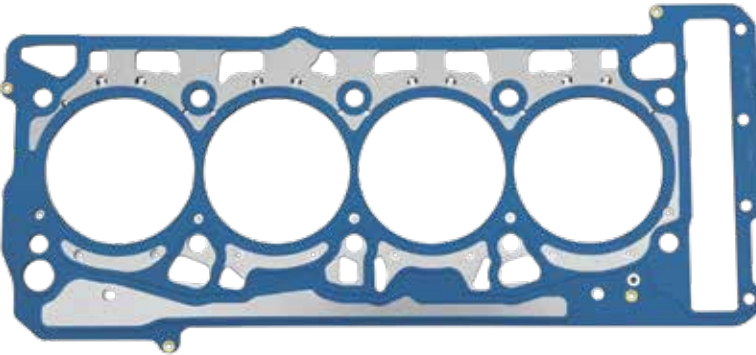

Generation IV

915.050 // OE # 06J 103 383 L

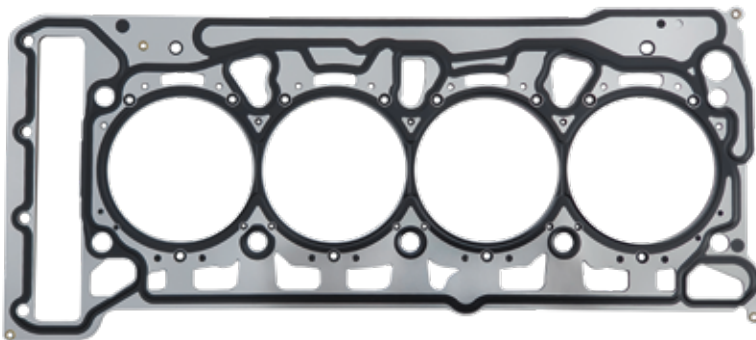

Generation I CHINA
Ø 83mm

915.160 // OE # 06J 103 383 AH

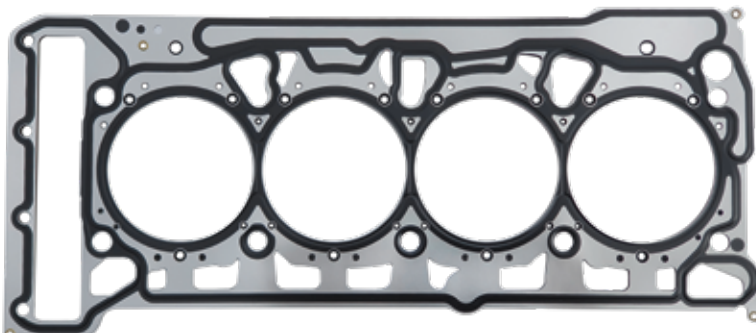



Generation III CHINA
Ø 83mm

EA888 Gen. I + II

1.8 | + 2.0 | TSI

Top Mover

	#	
 244.891	-	Audi: A3 A4 A5 A6 A8 Q3 Q5 TT Seat: Alhambra Altea Exeo Leon Skoda: Octavia Superb Yeti VW: Amarok Beetle California T5 California T6 CC Eos Golf Jetta Multivan T5 Multivan T6 Passat Scirocco Sharan Tiguan Transporter T5 Transporter T6 Magotan
 295.780	-	Audi: A3 A4 A5 TT Seat: Altea Leon Toledo Skoda: Octavia Superb VW: Passat Magotan Sagitar
 430.920	-	Audi: A4 A5 Q5
 766.790	-	Audi: Q3 Skoda: Octavia Superb Yeti VW: CC Golf Tiguan Passat Magotan Sagitar
 903.201	-	Audi: A3 A4 A5 A6 A8 Q3 Q5 TT Seat: Alhambra Altea Exeo Leon Toledo Skoda: Octavia Superb Yeti VW: Amarok Beetle CC Eos Golf Jetta Passat Scirocco Sharan Tiguan Magotan Sagitar
 685.662	06H 103 383 AF	Audi: A3 A4 A5 A6 A8 Q3 Q5 TT Seat: Alhambra Altea Exeo Leon Toledo Skoda: Octavia Superb Yeti VW: Amarok Beetle CC Eos Golf Jetta Multivan T5 Multivan T6 Passat Scirocco Sharan Tiguan Transporter T5 Magotan Sagitar
 325.930	06D 103 385 D	Audi: A1 A3 A4 A5 A6 A8 Q3 Q5 TT Seat: Alhambra Altea Exeo Leon Toledo Skoda: Octavia Superb Yeti VW: Amarok Beetle California T5 California T6 CC Eos Golf Jetta Multivan T5 Multivan T6 Passat Polo Scirocco Sharan Tiguan Transporter T5 Transporter T6 Magotan Sagitar
 323.300	WHT 005 305	Audi: A1 A3 A4 A5 A6 A7 A8 Q2 Q3 Q5 Q7 Q8 TT Seat: Alhambra Altea Ateca Exeo Ibiza Leon Tarraco Skoda: Karoq Kodiaq Octavia Superb Yeti VW: Arteon Atlas Beetle CC Eos Golf Jetta Passat Polo Scirocco Sharan Tiguan Touareg Touran T-Roc Lamando Magotan Sagitar Phideon Talagon Tavendor Tayron Teramont Tharu Viloran



766.790



261.190



903.201



485.410 // OE # 06J 998 907 D

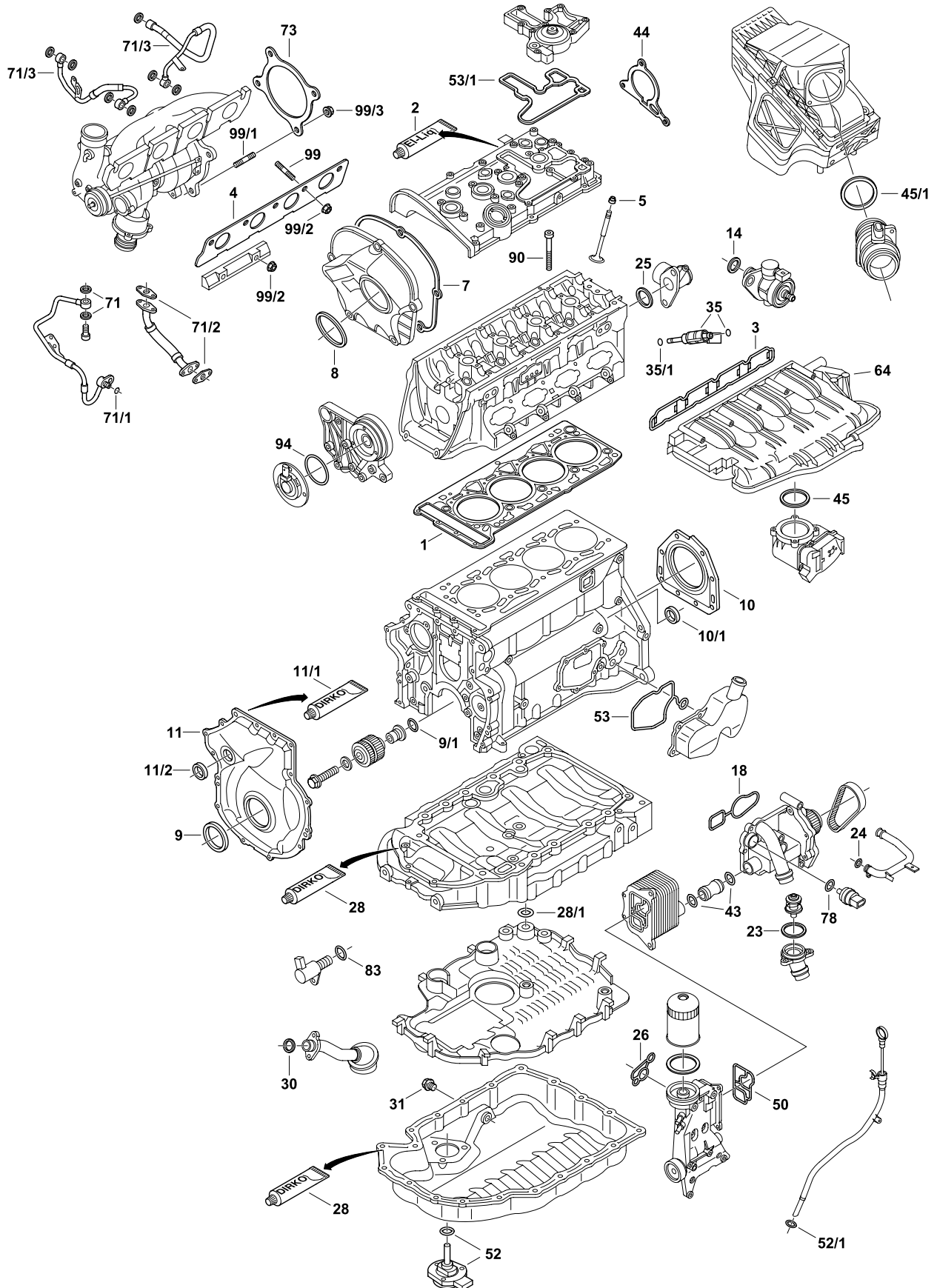



	244.891	1	-	± 0,9 mm	Gen. II
	295.780	1	-	± 0,9 mm	Gen. I
	430.920	1	-	± 0,9 mm	Gen. II E85
	766.790	1	-	± 0,9 mm	Gen. I CHINA
	903.201	1	-	-	-
	325.930	1	06D 103 385 D (10x)	M10x1,5x117 10.9	
	323.300	1	WHT 005 305 (10x)	M10x1,5x115 12.9	
	261.160	1	-	-	for OE No. 06J145701B, 06J145701G, 06J145701H, 06J145701J, 06J145701L, 06J145701P, 06J145701R, 06J145701T, 06J145702C, 06J145702F, 06J145702K, 06J145713A, 06J145713D, 06J145713F, 06J145713K, 06J145713T, 06J145722B
	948.660	1	-	-	for OE No. 06H145701K, 06H145701L, 06H145703R, 06H145713D
	261.190	1	-	-	for OE No. 06D145701E, 06D145701G, 06D145701H, 06D145701J
	235.610	1	036 109 675 A (16x)	6x8,8/12,2x9,3 FPM	
	485.410	4	06J 998 907 D	-	for OE No. 06H906036 E/G/H, 06H906036N, 06K906036, 06L906036J
	445.950	4	06G 998 907	-	for OE No. 04E906036E, 04E906036N, 06G906036, 06G906036 AF/AK/AJ, 06G906036 B/F, 06G906036 K/L/Q, 06G906036 R/S/T, 06H906036P, 06K906036N, 06L906036 AC/AG, 06L906036 E/J/L/T
1	685.662	1	06H 103 383 AF	Ø 83,3mm ± 0,9mm	-
2	461.682	1	-	-	
3	655.840	1	06F 129 717 D	-	Gen. II
3	735.850	1	06J 129 717	-	Gen. I
4	150.860	1	06F 253 039 F	-	-
5	724.590	16	036 109 675 A	6x8,8/12,2x9,3 FPM	-
7	240.290	1	06H 103 483 C	-	-
8	217.320	1	06H 103 483 D	-	-

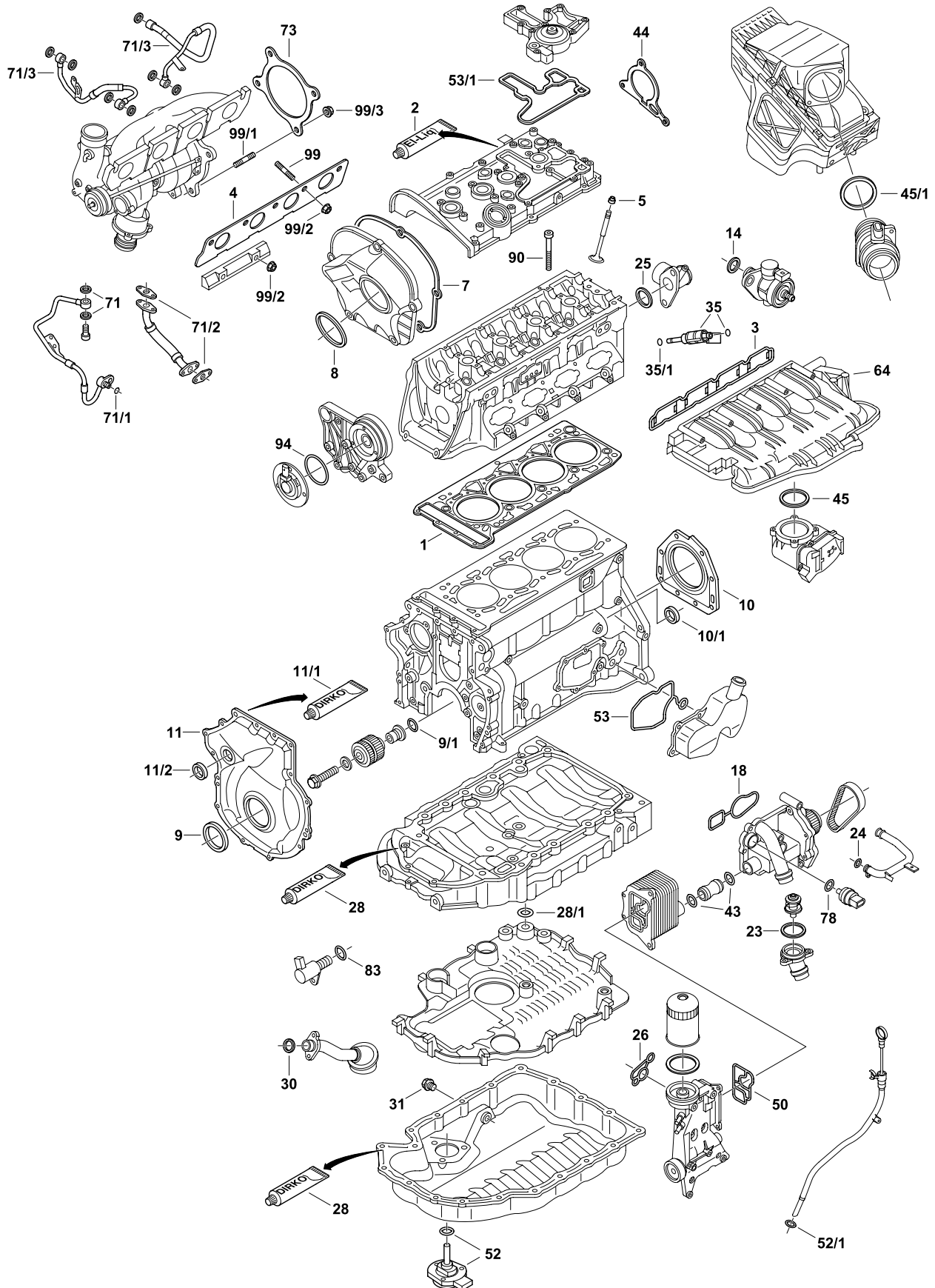



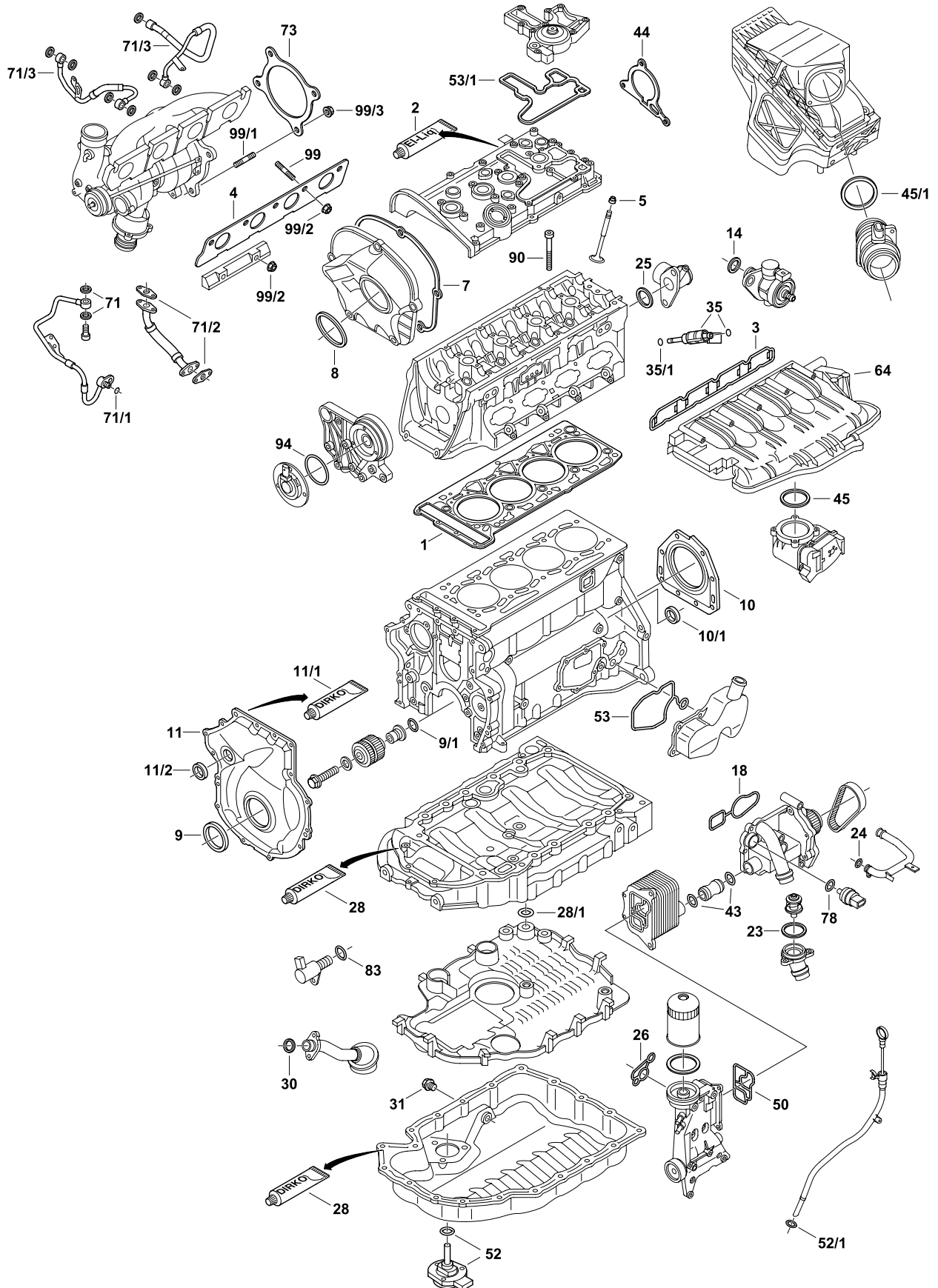

9	248.300	1	06L 103 085 B	45x60x8 RD → ASW PTFE/AEM	-
9/1	818.526	1	WHT 001 905	O-Ring 10,3x2,4 FPM	-
10	798.660	1	06K 103 171 P	Ø 85mm IWDR FE/PTFE/ACM	-
10/1	790.650	1	06H 103 085 J	15x36x7 AW RD → PTFE/AEM	-
11	886.650	1	06H 109 210 AG	-	Gen. I
11	231.851	1	06K 109 210 AF	-	Gen. II
11/1	036.164	1	-	-	Dirko™ HT
11/2	694.420	1	06H 115 418 AA	Ø 26,4 mm	-
14	174.270	1	06E 127 248	O-Ring 31,5x2 FPM	-
18	236.880	1	06H 121 119 D		-
23	382.550	1	06J 121 119 B	O-Ring 48,7x3 EPDM	-
24	588.400	1	N 903 653 02	O-Ring 20x3 EPDM	-
25	839.270	1	WHT 001 688	O-Ring 32x3 FPM	-
26	898.000	1	06J 115 441 A	-	-
28	036.164	1	-	-	Dirko™ HT
28/1		1	06J 103 147	-	-
30	733.490	1	N 028 222 2	O-Ring 20x3 FPM	-
31	858.040	1	N 911 679 01	M14	
31	966.180	1	N 016 027 6	M14	
31	858.050	1	N 013 815 7	M14	with seal ring mit Dichtring avec bague d'étanchéité con junta tórica con anello ten uta z pierścieniem uszczelniającym
31/1	591.840	1	N 013 815 8	14x20x2 DIN 7603 C Fe	-
31/1	813.036	1	N 013 815 6	14x20x2 DIN 7603 C Cu	-
35	904.050	4	-	O-Ring 5,94x3,53 FPM	-
35/1		4	-	6,1x7,8x3,2 PTFE	-
43		2	WHT 002 001	O-Ring 16x3 EPDM	-
44	443.020	1	06H 103 121 J	Metaloseal™	-
44	226.460	1	06H 103 121 F	Metaloseal™	-
45	898.640	1	06H 133 073	FPM	-
45	729.960	1	06F 133 073 D	FPM	-
45/1	897.580	1	357 129 625 A	O-Ring 79x6 NBR	-
50	898.010	1	06J 117 070 C		-
52	351.210	1	038 103 196 B	AEM	-
52/1	904.470	1	WHT 003 463	O-Ring 11,8x2,5 FPM	-
53	789.960	1	06H 103 517 D	-	-



















53/1	886.660	1	06H 103 484 A	-	-
64	B04.000	1	06J 133 185 BH	-	Audi A3 Audi Q3 Audi TT Alhambra Altea Leon Octavia Superb Yeti Beetle CC Eos Golf Jetta Passat Scirocco Sharan Tiguan Magotan Sagitar
71	239.402	2	N 013 851 4	12x18x1,5 Al A	-
71/1	647.740	1	N 900 672 02	O-Ring 9,5x2,5 FPM	-
71/2	090.530	2	06F 145 757 M	Metaloseal™	-
71/3	242.608	6	N 013 814 9	14x18x1,5 Al A DIN 7603	-
73	244.600	1	8K0 253 115 L	-	-
73	150.060	1	8E0 253 115 D	-	-
73	462.040	1	1K0 253 115 AB	-	-
78	240.140	1	N 903 168 01	O-Ring 19,6x3,65 EPDM	-
83	915.718	1	N 910 568 01	O-Ring 12x2 FPM	-
90	325.930	10	06D 103 385 D	M10x1,5x117 10.9	
90	323.300	10	WHT 005 305	M10x1,5x115 12.9	
94	538.010	1	WHT 007 212 B	O-Ring 52x3 FPM	-
99	245.710	5	N 014 555 5	M8x44	-
99	261.140	4	06F 103 397	M8x40	-
99/1	372.170	4	N 107 302 01	M10x30	-
99/2	247.130	9	N 908 946 01	M8	-
99/3	-	4	WHT 002 514	M10	-

EA888 Gen. III 2.0 | TSI

Top Mover

	#		
	770.530	-	Audi: A4 A5 A6 A7 A8 Q3 Q5 Q7 TT VW: Tiguan Touareg
	847.100	-	Audi: A4 A5 A6 A7 Q7
	847.090	-	Audi: A4 A5
	313.201	-	Audi: A1 A3 Q3 TT Seat: Alhambra Ibiza Leon Skoda: Kodiaq Octavia Superb VW: Arteon Atlas Beetle Golf Jetta Passat Polo Scirocco Sharan Tiguan Touran CC Lamando Magotan Tayron Teramont Tiguan
	503.950	-	Audi: A1 A3 Q2 Q3 TT Seat: Ateca Leon Tarraco Skoda: Karoq Kodiaq Octavia Superb VW: Arteon Golf Passat Polo Tiguan T-Roc
	497.040	-	VW: Beetle Passat Tiguan
	877.300	-	Audi: A4 A5 A6 A7 Q5 Q7 Q8 VW: Touareg
	877.340	-	Audi: A4 A5 A6 A7 A8 Q5
	798.670	-	Audi: A1 A3 Q2 Q3 TT Seat: Alhambra Ibiza Leon Tarraco Skoda: Karoq Kodiaq Octavia Superb VW: Arteon Beetle Golf Passat Polo Scirocco Sharan Tayron Teramont Tiguan Touran T-Roc
	008.040	06K 103 383 K	Audi: A1 A3 A4 A5 A6 A7 A8 Q2 Q3 Q5 Q7 Q8 TT Seat: Alhambra Ateca Ibiza Leon Tarraco Skoda: Karoq Kodiaq Octavia Superb VW: Arteon Atlas Beetle Golf Jetta Passat Polo Scirocco Sharan Tiguan Touareg Touran T-Roc CC Lamando Magotan Tayron Teramont Tiguan
	323.300	WHT 005 305B	Audi: A1 A3 A4 A5 A6 A7 A8 Q2 Q3 Q5 Q7 Q8 TT Seat: Alhambra Altea Exeo Ibiza Leon Tarraco Skoda: Karoq Kodiaq Octavia Superb Yeti VW: Arteon Beetle CC Eos Golf Jetta Lamando Magotan Passat Polo Sagitar Scirocco Sharan Talagon Tavendor Tayron Teramont Tharu Tiguan Touareg T-Roc Viloran
	112.130	WHT 009 271	Audi: A1 A3 A4 A5 A6 A7 Q2 Q3 Q5 Q7 Q8 TT Seat: Alhambra Ateca Leon Tarraco Skoda: Karoq Kodiaq Octavia Superb VW: Arteon Golf Multivan T7 Passat Polo Sharan Tiguan Touareg T-Roc



770.530

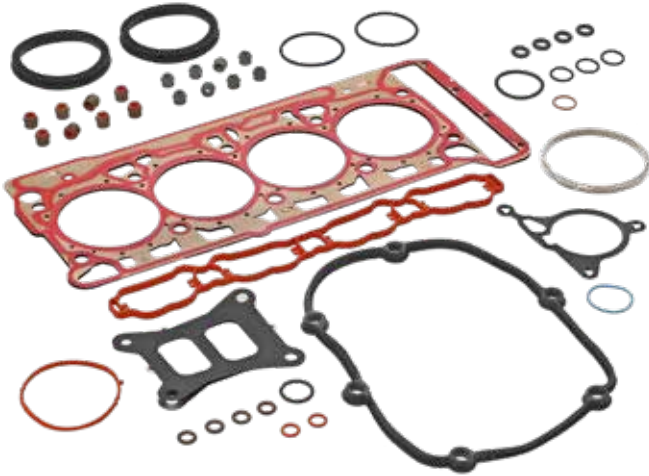

503.950

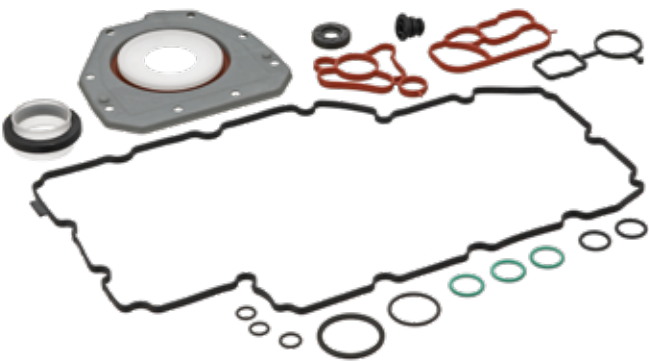

877.300

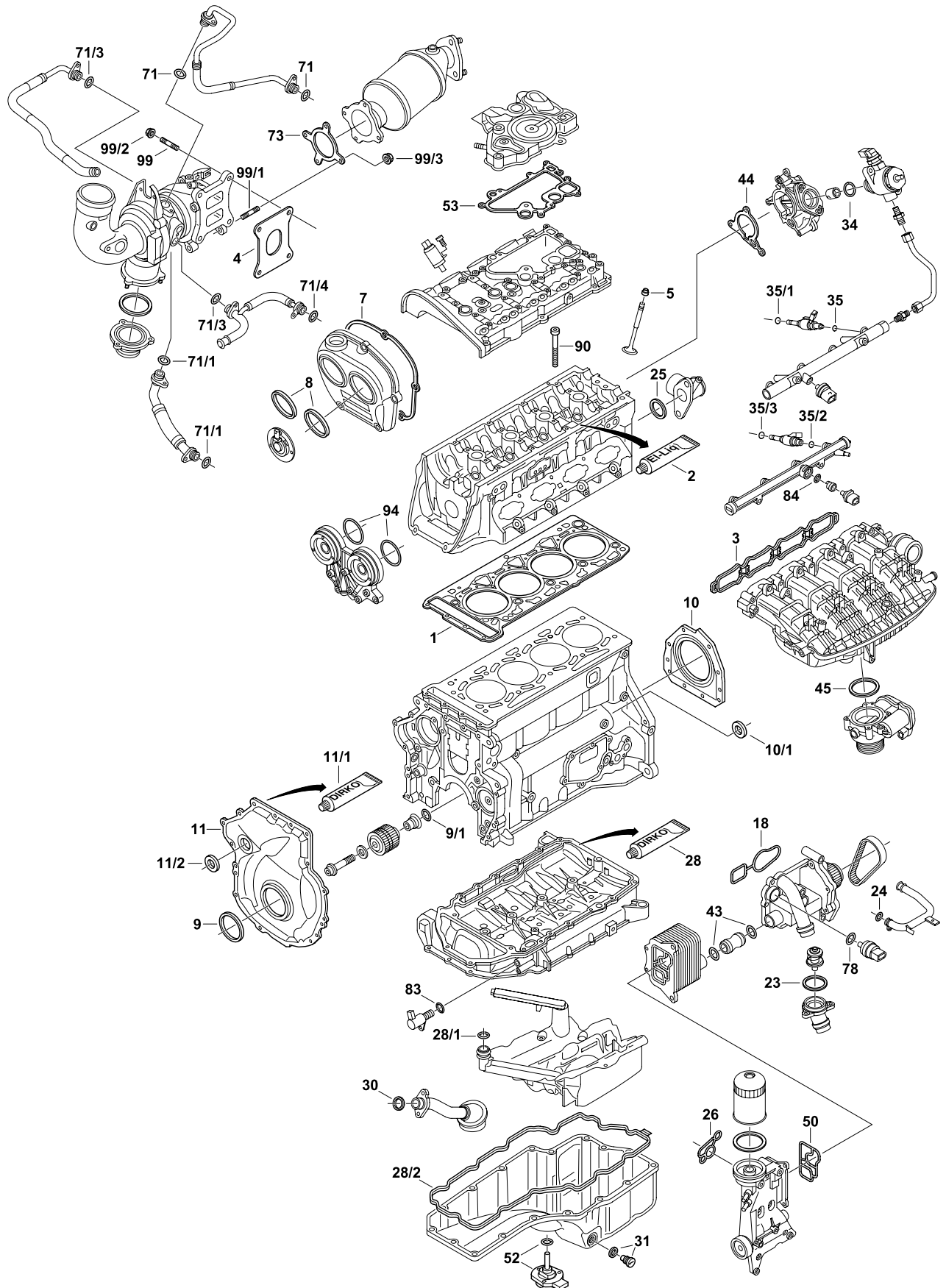



	770.530	1	-	$\pm 0,9 \text{ mm}$	-
	847.100	1	-	$\pm 0,9 \text{ mm}$	-
	847.090	1	-	$\pm 0,9 \text{ mm}$	-
	313.201	1	-	$\pm 0,9 \text{ mm}$	-
	503.950	1	-	-	-
	497.040	1	-	-	-
	877.300	1	-	-	-
	877.340	1	-	-	-
	798.670	1	-	-	-
	323.300	1	WHT 005 305 (10x)	M10x1,5x115 12.9	
	112.130	1	WHT 009 271	M10x1,5x115	
	793.230	1	-	-	for OE No. 06K145701E, 06K145701L, 06K145701M, 06K145701N, 06K145701S, 06K145701T, 06K145702G, 06K145713J, 06K145715B, 06K145715C, 06K145715D, 06K145715F, 06K145722A, 06L145701E, 06L145701F, 06L145701G, 06L145701H, 06L145701J, 06L145701K, 814000- 0015, 814000-5015S, 819035- 0011, 819035-0013, 819035-0017, 819035-5011S, 819035-5013S, 819035-5017S
	878.330	1	-	-	for OE No. 06L145654C, 06L145654F, 06L145654G, 06L145722D, 06L145722M, 06L145722T, 06L145874E, 95814570200, 95814570210
	872.370	1	-	-	
	445.950	4	06G 998 907	-	for OE No. 04E906036E, 04E906036N, 06G906036, 06G906036 AF/AK/AJ, 06G906036 B/F, 06G906036 K/L/Q, 06G906036 R/S/T, 06H906036P, 06K906036N, 06L906036 AC/AG, 06L906036 E/J/L/T
1	008.040	1	06K 103 383 K	$\varnothing 83,3\text{mm} \mid \pm 0,9\text{mm}$	-
2	461.682	1	-	-	

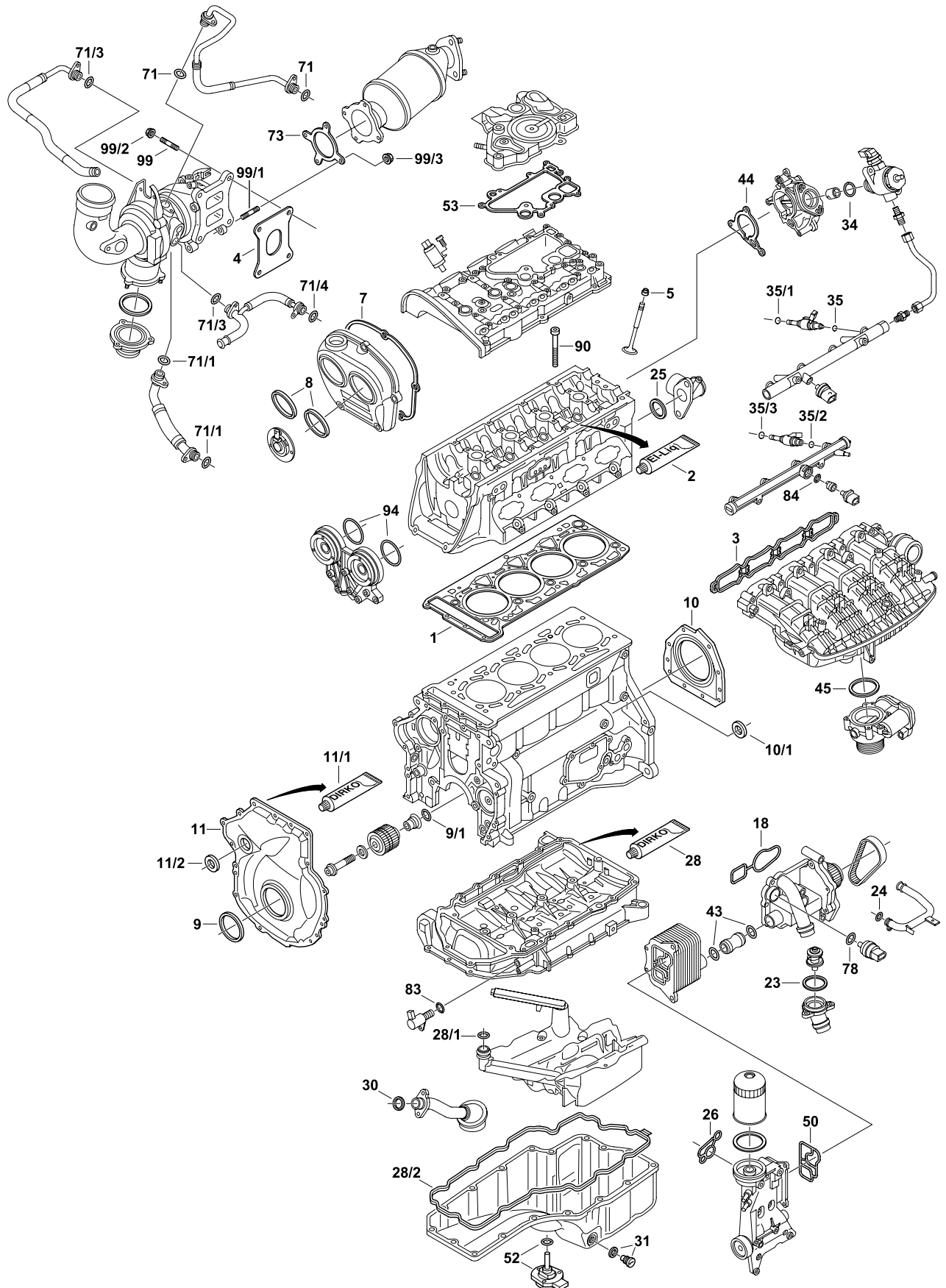



3	297.590	1	06K 129 717 A	-	
3	948.030	1	06K 129 717 H	-	Audi A3 Audi A4 Audi Q3 Audi Kodiaq Superb Beetle Passat Tiguan Allspace (NAFTA) CC Magotan Talagon Tavendor Tayron Tharu Tiguan Viloran
3	822.390	1	06K 129 717 K	-	-
4	691.780	1	06L 253 039	-	-
5	724.590	8	036 109 675 A	6x8,8/12,2x9,3 FPM	
5	797.560	8	06L 109 675 C	6x8,8/12,4x11 FPM	
7	268.000	1	06K 103 483	-	-
8	302.690	2	06K 103 583	-	-
9	248.300	1	06L 103 085 B	45x60x8 ASW RD → PTFE/ACM	-
9/1	818.526	2	WHT 001 905 A	O-Ring 10,3x2,4 FPM	-
10	798.660	1	06K 103 171 P	Ø 85mm IWDR LD ← FE/PTFE/ACM	-
10/1	790.650	1	06H 103 085 J	15x36x7 AW RD → PTFE/ACM	-
10/1	299.640	1	06K 103 085	15x7 RD → PTFE	-
11	231.851	1	06K 109 210 AF	-	Gen. II
11/1	036.164	1	-	-	Dirko™ HT
11/2	694.420	1	06H 115 418 AA	Ø 26,4 mm	-
18	453.710	1	06L 121 139 A	-	-
23		1	-	-	-
24		1	-	-	-
25	839.270	1	WHT 001 688	O-Ring 32x3 FPM	-
26	279.630	1	06L 115 441	-	-
28	036.164	1	-	-	Dirko™ HT
28/1	733.490	2	N 028 222 2	O-Ring 20x3 FPM	-
28/2	478.650	1	06L 103 649 R	-	Audi A4 Audi A5 Audi A6 Audi A7 Audi Q5 Audi Q7 Audi Q8
28/2	822.480	1	06L 103 649 S	-	Audi A6 Audi A7 Audi A8
28/2	398.260	1	06K 103 649 J	-	Audi A1 Audi A3 Audi Q2 Arteon Polo Tiguan T-Roc
30	733.490	1	N 028 222 2	O-Ring 20x3 FPM	-
31	588.690	1	06L 103 801	-	
34	174.270	1	06E 127 248	O-Ring 31,5x2 FPM	-
35	904.050	4	-	O-Ring 5,94x3,53 FPM	-

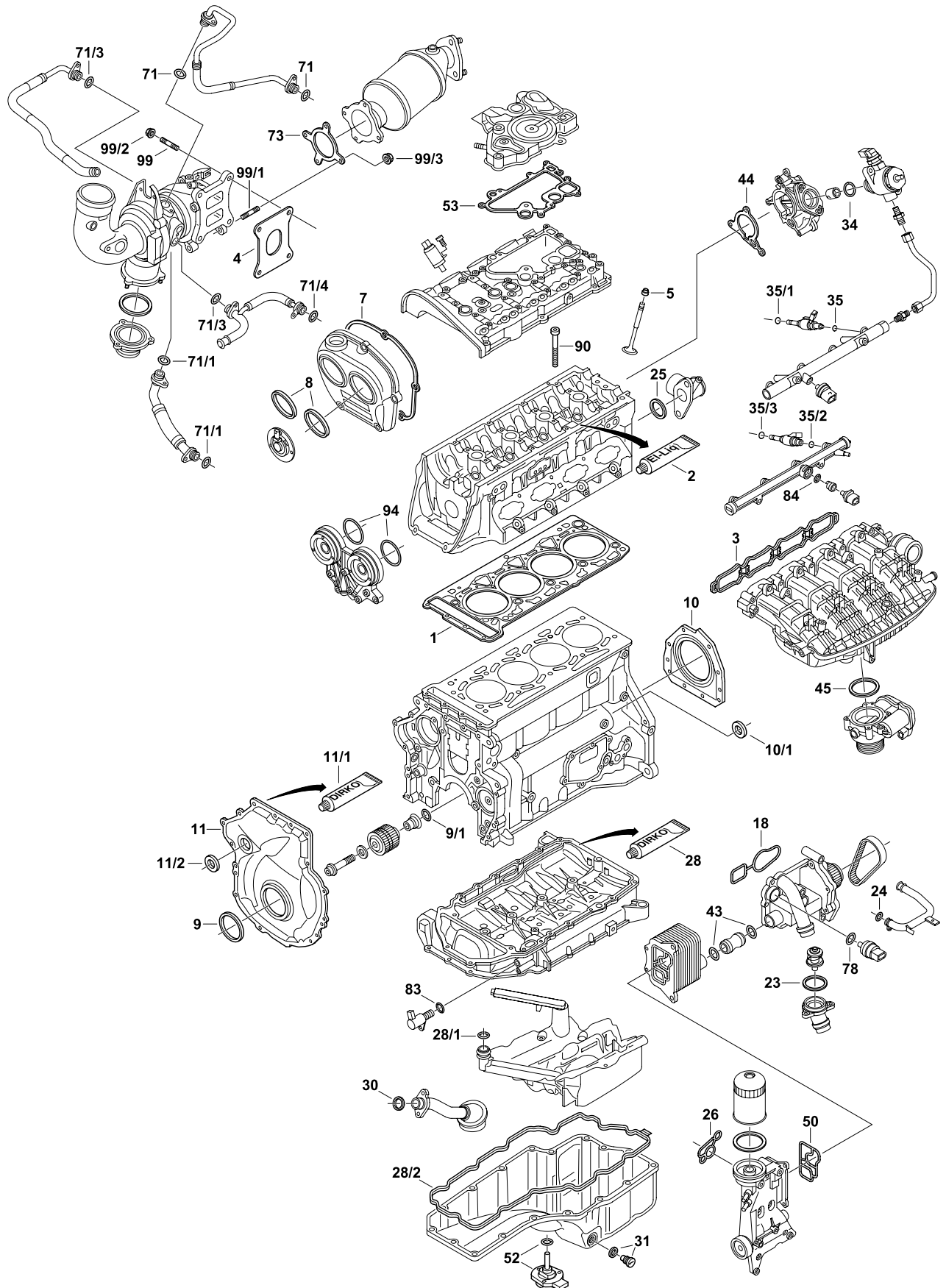











35/1		4	-	6,1x7,8x3,2 PTFE	-
35/2	234.480	4	06A 906 149 B	O-Ring 8,3x3,1 FPM	-
35/3	893.889	4	WHT 005 422 B	O-Ring 7,52x3,53 FPM	-
43	424.790	2	WHT 004 973	O-Ring 18x3 EPDM	-
44	443.020	1	06H 103 121 J	Metaloseal™	-
45	480.140	1	06K 133 073 D	-	-
45	480.210	1	06K 133 073	-	-
50	279.610	1	06L 117 070	-	-
52	351.210	1	038 103 196 B	-	-
53	852.590	1	06K 103 484 F	-	-
71	647.740	2	N 900 672 02	O-Ring 9,5x2,5 FPM	-
71/1	456.670	1	WHT 006 112	O-Ring 16,6x1,7 FPM	-
71/2	456.680	1	WHT 006 113	O-Ring 15x1,8 FPM	-
71/3	793.220	2	WHT 006 114	O-Ring 15x2 EPDM	-
71/4	588.400	1	WHT 006 124	O-Ring 20x3 EPDM	-
73	244.600	1	8K0 253 115 L	Metaloseal™	-
73	738.820	1	5Q0 253 115 B	84,4x92,4x5,9 GLIMMER	-
73/1	644.200	1	5Q0 253 725 G	-	-
78	569.390	1	N 903 168 01	O-Ring 19,6x3,6 EPDM	-
83	915.718	1	N 910 568 01	O-Ring 12x2 FPM	-
84	915.718	1	N 910 568 01	O-Ring 12x2 FPM	-
90	323.300	10	WHT 005 305 B	M10x1,5x115 12.9	
90	112.130	10	WHT 009 271	M10x1,5x115 12.9	
94	538.010	2	WHT 007 212 B	O-Ring 52x3 FPM	-
99		4	N 912 317 01	M8x22	-
99/1	372.170	4	N 107 302 01	M10x32	-
99/2	456.430	4	WHT 007 210	M8	
99/3	380.530	4	N 102 861 11	M10	-

EA888 Gen. IV 2.0 | TSI

Top Mover

	#		
	908.020	-	Audi: A1 A3 Q2 Q3 TT Seat: Ateca Leon Tarraco Skoda: Karoq Kodiaq Octavia Superb VW: Arteon Golf Passat Tiguan T-Roc
	893.200	-	Audi: A4 A5 A6 A7 Q3 Q5 Q8 Seat: Tarraco Skoda: Kodiaq Octavia Superb VW: Golf Multivan T7 Passat Tiguan
	877.300	-	Audi: A4 A5 A6 A7 Q5 Q7 Q8 VW: Touareg
	798.670	-	Audi: A1 A3 Q2 Q3 TT Seat: Alhambra Ateca Ibiza Leon Tarraco Skoda: Karoq Kodiaq Octavia Superb VW: Arteon Beetle CC Golf Lamando Magotan Passat Polo Scirocco Sharan Tiguan Touran T-Roc Tayron Teramont
	564.670	06N 103 383 A	Audi: A1 A3 A4 A5 Q2 Q3 TT Seat: Ateca Leon Tarraco Skoda: Karoq Kodiaq Octavia Superb VW: Arteon Golf Passat Tiguan T-Roc
	564.640	06N 103 383 B	Audi: A4 A5 A6 A7 Q3 Q5 Q8 Seat: Tarraco Skoda: Kodiaq Octavia Superb VW: Golf Multivan T7 Passat Tiguan
	893.170	06Q 103 383 A	Audi: A3 Q2 TT Skoda: Superb VW: Arteon Golf Passat Tiguan T-Roc
	112.130	WHT 009 271	Audi: A1 A3 A4 A5 A6 A7 Q2 Q3 Q5 Q7 Q8 TT Seat: Alhambra Ateca Leon Tarraco Skoda: Karoq Kodiaq Octavia Superb VW: Arteon Golf Multivan T7 Passat Polo Tiguan Touareg T-Roc

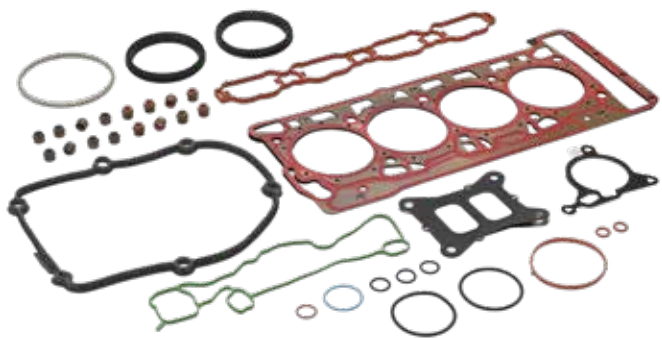

908.020

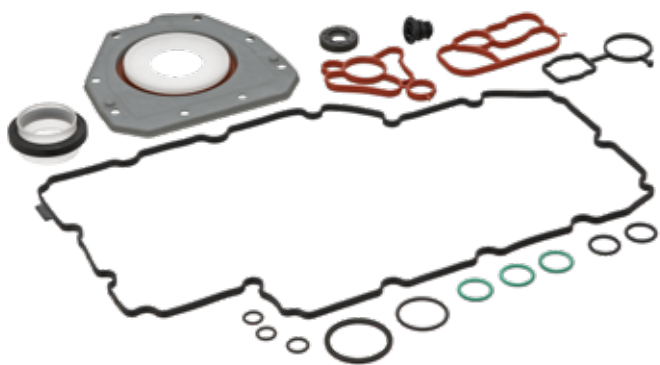

877.300



033.070

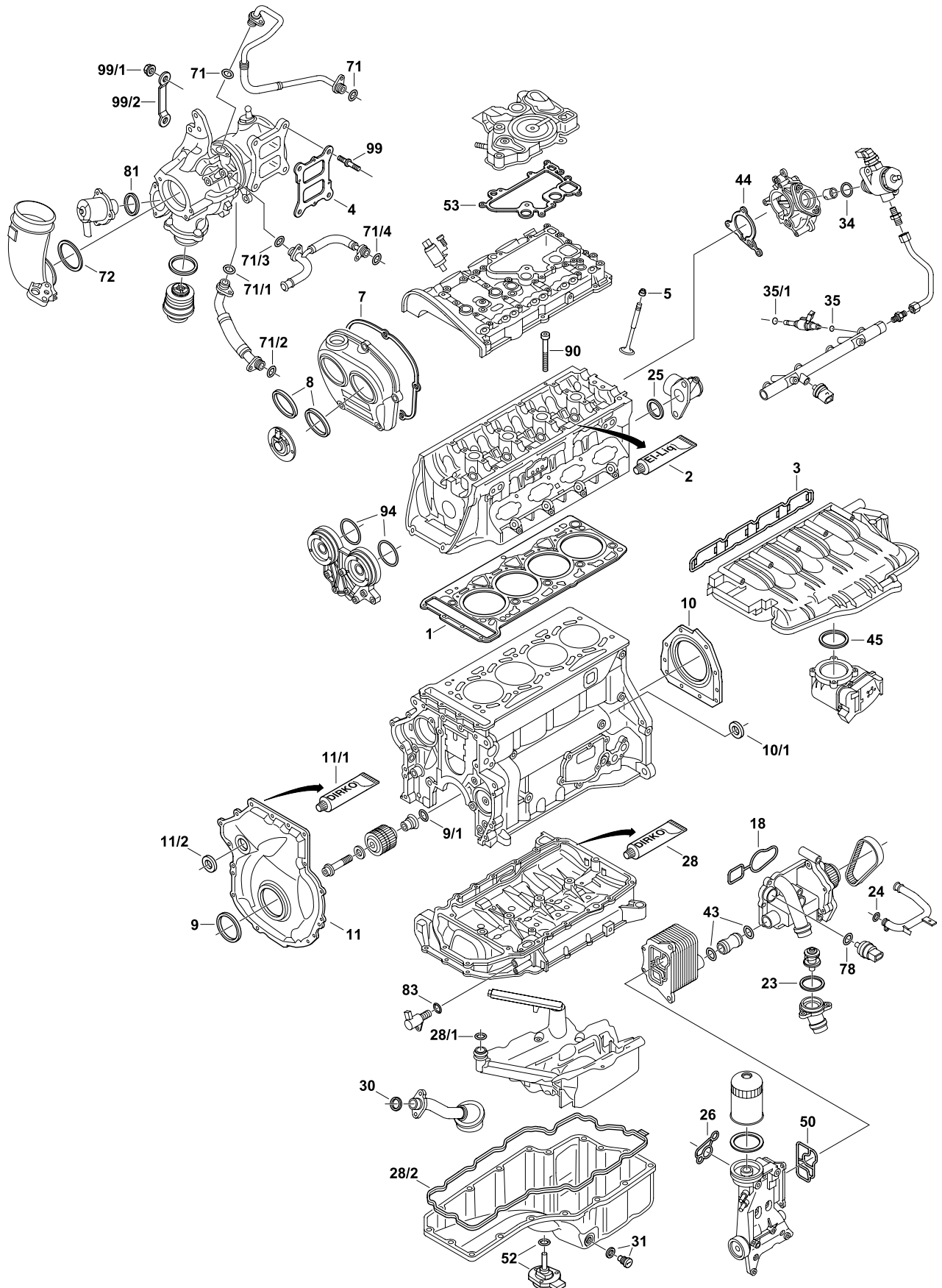



	908.020	1	-	-	-> 150kW
	893.200	1	-	-	150kW ->
	877.300	1	-	-	-
	798.670	1	-	-	-
	112.130	1	WHT 009 271 (10x)	M10x1,5x115 12.9	
	033.070	1	-	-	-
	041.450	1	-	-	-
		4	06N 906 907	-	-
		4	06Q 906 907	-	-
		4	06Q 906 907 A	-	-
	031.320	1	-	-	
1	564.670	1	06N 103 383 A	Ø 83,3mm $\frac{\pm}{\mu}$ 0,9mm	-> 150kW
1	564.640	1	06N 103 383 B	Ø 83,3mm $\frac{\pm}{\mu}$ 0,9mm	150kW ->
1	893.170	1	06Q 103 383 A	-	202kW ->
2	461.682	1	-	-	
3	822.390	1	06K 129 717 K	-	-> 150kW
3	297.590	1	06K 129 717 A	-	150kW ->
4	691.780	1	06L 253 039	-	-
5	724.590	8	036 109 675 A	6x8,8/12,2x9,3 FPM	
5	797.560	8	06L 109 675 C	6x8,8/12,4x11 FPM	
7	893.820	1	06Q 103 483 A	-	-
8	893.790	2	06Q 103 583 A	-	-
9	248.300	1	06L 103 085 B	45x60x8 ASW RD $\frac{\pm}{\mu}$ PTFE/ACM	-
9/1	818.526	2	WHT 001 905 A	O-Ring 10,3x2,4 FPM	-
10	798.660	1	06K 103 171 P	Ø 85mm IWDR LD $\frac{\pm}{\mu}$ FE/PTFE/ACM	-
10/1	790.650	1	06H 103 085 J	15x36x7 AW RD $\frac{\pm}{\mu}$ PTFE/ACM	-
10/1	299.640	1	06K 103 085	15x7 RD $\frac{\pm}{\mu}$ PTFE	-
11		1	06Q 109 210	-	-
11/1	036.164	1	-	-	Dirko™ HT
11/2	694.420	1	06H 115 418 AA	Ø 26,4 mm ACM	-
18	453.710	1	06L 121 139 A	-	-

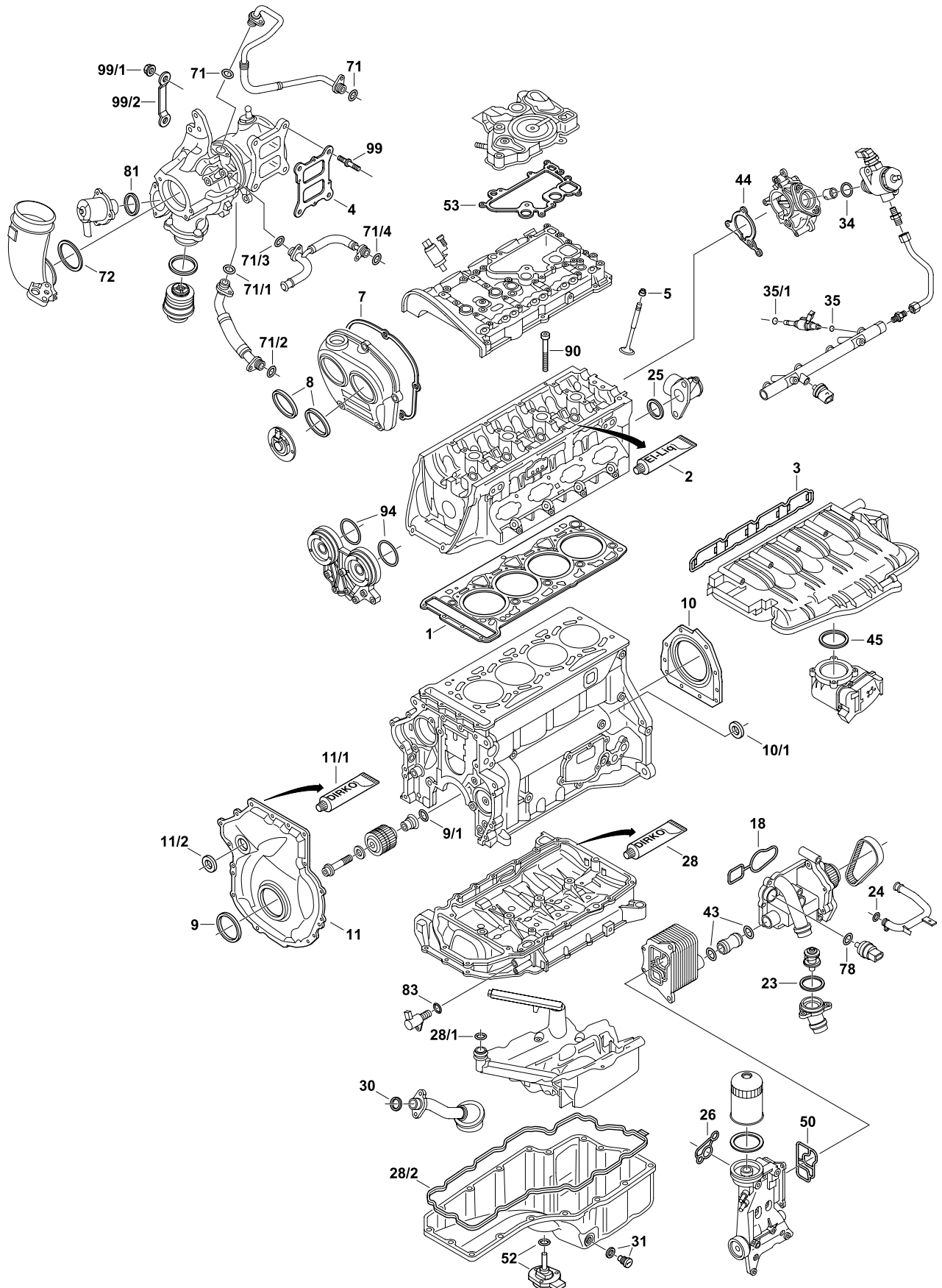



23		1	-	-	-
24		1	-	-	-
25	839.270	1	WHT 001 688	O-Ring 32x3 FPM	-
26	279.630	1	06L 115 441	-	-
28	036.164	1	-	-	Dirko™ HT
28/1	733.490	2	N 028 222 2	O-Ring 20x3 FPM	-
28/2	478.650	1	06L 103 649 R	-	Audi A4 Audi A5 Audi Q5 Audi Q7
28/2	822.480	1	06L 103 649 S	-	Audi A6 Audi A7 Audi A8
28/2	398.260	1	06K 103 649 J	-	Audi A1 Audi A3 Audi Q2 Arteon Polo Tiguan T-Roc
30	733.490	1	N 028 222 2	O-Ring 20x3 FPM	-
31	588.690	1	06L 103 801		-
34	174.270	1	06E 127 248	O-Ring 31,5x2 FPM	-
35		4	-	-	-
35/1		4	-	-	-
43	424.790	2	WHT 004 973	O-Ring 18x3 EPDM	-
44	895.080	1	06N 103 121	-	-
45	480.140	1	06K 133 073 D	-	-> 150kW
45	480.210	1	06K 133 073	-	150kW ->
50	279.610	1	06L 117 070	-	-
52	351.210	1	038 103 196 B	-	-
53	852.590	1	06K 103 484 F	-	-
53	910.430	1	06Q 103 484 A	-	-
71	647.740	2	N 900 672 02	O-Ring 9,5x2,5 FPM	-
71/1	456.670	1	WHT 006 112	O-Ring 16,6x1,7 FPM	-
71/2	456.680	1	WHT 006 113	O-Ring 15x1,8 FPM	-
71/3	793.220	2	WHT 006 114	O-Ring 15x2 EPDM	-
71/4	588.400	1	WHT 006 124	O-Ring 20x3 EPDM	-
72		1	WHT 010 054	O-Ring 50,1x5,34 FPM	-
72		1	WHT 010 054 A	O-Ring 66x3,53 FPM	-
72/1		1	WHT 010 055	-	-
73	912.290	1	5Q0 253 115 C	99x107x3,9 GLIMMER	-
73/1	915.980	1	5WA 253 725	-	-
78		1	WHT 002 287	O-Ring 5,6x2 FPM	-
81		1	-	-	-

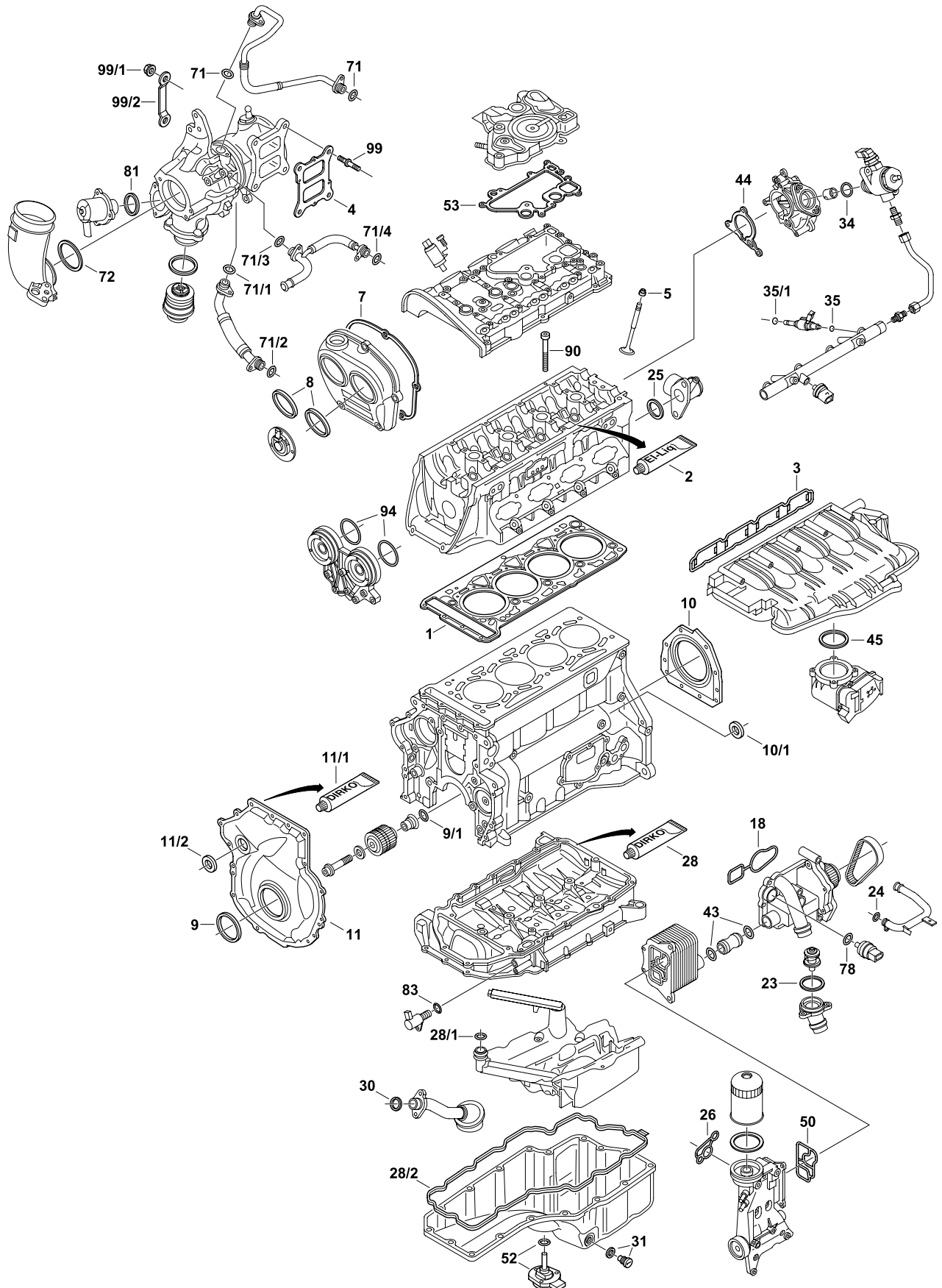



83	915.718	1	N 910 568 01	O-Ring 12x2 FPM	-
90	112.130	10	WHT 009 271	M10x1,5x115 12.9	
94	538.010	2	WHT 007 212 B	O-Ring 52x3 FPM	-
99		4	WHT 009 402	M8x53	-
99/1	456.430	4	WHT 007 210	M8	
99/2		2	06Q 145 039 B	-	-



Oil seals | Radialwellendichtringe |
Bagues à lèvres radiales | Retenes
radiales | Anelli paraolio radiali |
Pierścienie



Valve Stem Seals |
Ventilschaftdichtungen | Joints
de queue de soupape | Retenes
de válvula | Guarnizioni per
fusi di valvole | Uszczelniacze
trzonka zaworu



Standard parts | Normteile |
Pièces normalisées | Piezas
normalizadas | Componenti
standardizzati | Części
znormalizowane



Assortments | Dichtungs-
sortimente | Assortiments de
joints | Surtidos de juntas |
Assortimenti di guarnizioni |
Asortyment uszczelnień



Social Media





Website



Newsletter



Online Catalog



Service Information



Instagram



WeChat



Facebook



1. Exclusion of liability

All information in this catalog has been carefully prepared by us. We accept no liability for the accuracy and completeness of data contained in this catalog. Any claim of damages against us arising from the use of the data contained in the catalog, or the use of any erroneous or incomplete data, is excluded. Subject to technical developments and changes. Before installing any replacement parts named in this catalog, it must be checked whether the parts are suitable for the intended purpose. Our technical service department is available for this at any time. In case of doubt, seek clarification. We expressly give notice that all replacement parts must be installed by trained, qualified personnel.

2. Notification of copyright and trademark law

The copyright for texts, graphics, and image documents created by us remains ours. Any imitation, reproduction, or use of such objects in other printed or electronic publications requires our written permission and citation of the source.

3. Terms and conditions

We give express notice that delivery is made exclusively under our general terms and conditions. The current edition of our general sales and delivery conditions is available on our Internet site, at: www.elring.de/agb_en We will be happy to send them to you upon request.

4. Miscellaneous

Names, descriptions, and numbers of vehicles and manufacturers and the like are intended solely for internal comparison purposes. The same applies to original spare part numbers from the vehicle and engine manufacturers. They are not an indication of origin and must not be used with vehicle owners.

Previous editions become obsolete with the publication of this catalog.

1. Haftungsausschluss

Sämtliche Angaben in diesem Katalog wurden von uns sorgfältig und fundiert bearbeitet. Wir übernehmen für die Richtigkeit und Vollständigkeit der im Katalog enthaltenen Angaben keine Gewähr. Sämtliche Ersatzansprüche gegen uns, die durch die Nutzung der im Katalog enthaltenen Angaben bzw. durch die Nutzung eventuell fehlerhafter oder unvollständiger Angaben verursacht wurden, sind ausgeschlossen. Laufende technische Entwicklungen oder Änderungen bleiben vorbehalten. Vor dem Einbau der in diesem Katalog genannten Ersatzteile ist zu prüfen, ob die Teile für den geplanten Verwendungszweck geeignet sind. Hierfür steht unser technischer Kundendienst jederzeit zur Verfügung. In allen Zweifelsfällen sollte Rücksprache erfolgen. Wir weisen ausdrücklich darauf hin, dass alle Ersatzteile von geschultem Fachpersonal eingebaut werden müssen.

2. Hinweise zum Urheber- und Kennzeichnungsrecht

Das Urheberrecht für die von uns erstellten Texte, Grafiken und Bilddokumente bleibt allein bei uns. Eine Nachahmung, Vervielfältigung oder Verwendung solcher Objekte in anderen gedruckten oder elektronischen Publikationen ist nur mit unserer schriftlichen Genehmigung und mit Quellenangabe gestattet.

3. AGB

Wir weisen ausdrücklich darauf hin, dass Lieferungen ausschließlich zu unseren Allgemeinen Verkaufs- und Lieferbedingungen erfolgen. Die aktuelle Fassung unserer Allgemeinen Verkaufs- und Lieferbedingungen ist auf unserer Internetseite unter: www.elring.de/agb_de veröffentlicht. Auf Wunsch senden wir Ihnen diese auch gerne zu.

4. Sonstiges

Namen, Beschreibungen, Nummern von Fahrzeugen und Herstellern und Ähnliches sind ausschließlich zu internen Vergleichszwecken bestimmt. Gleiches gilt für Original-Ersatzteilnummern der Fahrzeug- und Motorenhersteller. Sie sind keine Herkunftsbezeichnung und dürfen Fahrzeugbesitzern gegenüber nicht verwendet werden.

Mit Erscheinen dieses Katalogs verlieren frühere Ausgaben ihre Gültigkeit.

1. Limitation de responsabilité

Nous avons apporté le plus grand soin à la rédaction et à la vérification des informations figurant dans ce catalogue. Toutefois, nous ne pouvons garantir de manière absolue l'exactitude et l'intégrité des informations fournies. En conséquence, nous ne pouvons en aucun cas être tenus responsables de tout préjudice résultant de l'utilisation des informations de ce catalogue ou de l'utilisation d'une information erronée ou incomplète. Nous nous réservons le droit de modifier ou d'adapter nos produits aux évolutions technologiques. Avant de procéder au montage des pièces de rechange citées dans ce catalogue, vérifiez si celles-ci sont adaptées à l'utilisation prévue. Notre service clientèle est à votre disposition pour tout renseignement à ce sujet. En cas de doute, il est fortement recommandé de lui demander conseil. Nous vous avisons explicitement que tout remplacement de pièce doit impérativement être effectué par des techniciens spécialisés.

2. Propriété intellectuelle et propriété industrielle

Tous les textes, graphismes et éléments visuels créés par nous nous sont réservés au titre de la propriété industrielle. A ce titre, toute reproduction, adaptation ou utilisation, totale ou partielle, sur un support papier ou informatique, ne pourra être faite sans notre autorisation écrite et sans citation explicite de la source.

3. CGV

Nous vous avisons explicitement que les présentes conditions générales de vente sont les seules applicables aux produits et services fournis par notre société. La version actuellement en vigueur de nos conditions générales de vente est disponible sur notre site Internet : www.elring.de/agb_en Celles-ci peuvent vous être envoyées par courrier sur simple demande.

4. Dispositions diverses

Les noms, descriptifs, numéros de véhicules et de constructeurs et autres références sont mentionnés à des fins exclusives de comparaison en interne. Ceci concerne également les numéros des pièces de rechange d'origine des constructeurs automobiles et motoristes. Ces numéros ne constituent pas une indication d'origine et ne doivent pas être utilisés à l'endroit des propriétaires des véhicules. Ce catalogue remplace et annule les éditions précédentes.



www.elring.com

1. Exención de responsabilidad

Todos los datos de este catálogo han sido elaborados de manera cuidadosa y fundamentada. La empresa no se responsabiliza por la corrección ni por la exhaustividad de los datos incluidos en el catálogo. No se admiten reclamaciones de indemnización derivadas del uso de datos incluidos en este catálogo o provocadas por la presencia de datos ocasionalmente erróneos o incompletos. La empresa se reserva el derecho de introducir modificaciones y mejoras técnicas. Antes de montar las piezas de recambio mencionadas en este catálogo, es necesario verificar si las piezas son adecuadas para el uso previsto. Nuestro servicio técnico de atención al cliente está siempre a su disposición. En caso de duda, debe realizarse la consulta correspondiente. Se hace constar expresamente que todas las piezas de recambio deben ser montadas por personal técnico cualificado.

2. Notas de copyright y derechos de autor

Los derechos de autor correspondientes a textos, gráficos e imágenes elaborados por la empresa son propiedad exclusiva de la empresa. La copia, reproducción o utilización de dichos elementos en otras publicaciones impresas o electrónicas sólo están permitidas si existe una autorización por escrito de la empresa y se menciona la fuente.

3. Condiciones Generales

Se hace constar expresamente que las entregas sólo tienen lugar en el marco de nuestras Condiciones Generales de Venta y Suministro. La versión vigente de las Condiciones Generales de Venta y Suministro está publicada en nuestro sitio de Internet en la dirección: www.elring.de/agb_en. Si lo desea, podemos enviarle un ejemplar.

4. Otros

Los nombres, las descripciones, los números de vehículos y fabricantes y similares se utilizan exclusivamente con fines comparativos a nivel interno. Lo mismo es válido para los números de piezas de recambio originales de los fabricantes de vehículos y motores. No son denominaciones de origen y no deben utilizarse ante los propietarios de los vehículos.

Con la aparición de este catálogo pierden su validez las versiones anteriores.

1. Esclusione di responsabilità

Tutti i dati riportati nel presente catalogo sono stati da noi accuratamente elaborati su basi fondate. Non forniamo alcuna garanzia riguardo all'esattezza e alla completezza dei dati riportati nel catalogo. È escluso qualsiasi diritto di rimborso nei nostri confronti, qualora sia dovuto all'applicazione dei dati contenuti nel catalogo, ovvero all'applicazione di eventuali dati errati o incompleti. Ci riserviamo di apportare eventuali modifiche o di adeguarci agli sviluppi tecnologici in corso. Prima di montare i pezzi di ricambio riportati nel presente catalogo, occorre verificare se i pezzi sono adeguati agli scopi d'utilizzo previsti. Il nostro servizio clienti per problematiche tecniche è a vostra completa disposizione. In caso di dubbio, rivolgersi sempre al servizio competente. Facciamo espressamente notare che tutti i pezzi di ricambio devono essere montati da personale tecnico qualificato.

2. Avvertenze sui diritti d'autore e sul diritto ad apporre il contrassegno

I diritti d'autore per i testi, i grafici e i documenti fotografici da noi prodotti sono di nostro esclusivo appannaggio. L'imitazione, la riproduzione o l'utilizzo di tali oggetti in altre pubblicazioni stampate o elettroniche sono consentite esclusivamente previa nostra autorizzazione scritta e con citazione della fonte.

3. CG

Facciamo espressamente notare che le spedizioni avvengono esclusivamente alle nostre condizioni generali di fornitura e di vendita. La versione attuale delle nostre condizioni generali di fornitura e di vendita può essere consultata sulla nostra pagina web: www.elring.de/agb_en. Su richiesta, saremo lieti di inviarvene una copia.

4. Varie

Nomi, descrizioni, numeri di veicoli e produttori, nonché altri dati analoghi sono destinati ai soli scopi comparativi interni. Lo stesso vale per i numeri dei pezzi di ricambio originali del produttore dei motori e del veicolo. Essi non presentano alcuna indicazione di origine e non devono essere utilizzati da parte del proprietario del veicolo. Con la pubblicazione del presente catalogo, le edizioni precedenti non sono più valide.

1. Wykluczenie odpowiedzialności

Wszystkie informacje przedstawione w niniejszym katalogu zostały przez nas opracowane z należytą starannością i dokładnością. Nie ponosimy odpowiedzialności za prawdziwość i kompletność informacji zawartych w katalogu. Wszelkie roszczenia wobec nas, których podstawę stanowi skorzystanie z zawartych w katalogu informacji lub skorzystanie z nieprawidłowych lub niekompletnych informacji, są wykluczone. Aktualny rozwój techniczny i zmiany są zastrzeżone. Przed przystąpieniem do montażu części zamiennych wymienionych w niniejszym katalogu należy sprawdzić, czy te części nadają się do planowanego celu zastosowania. W tym zakresie można się zwrócić w dowolnym momencie do naszego działu technicznego. Kontakt jest zalecany w razie jakichkolwiek wątpliwości. Wyraźnie podkreślamy, że wszystkie części zamienne muszą być montowane przez wykwalifikowany personel specjalistyczny.

2. Informacje dot. prawa autorskiego i etykietowania

Prawa autorskie do opracowanych przez nas tekstów, grafik i dokumentów graficznych przysługują wyłącznie nam. Kopiowanie, powielanie lub wykorzystywanie tego typu obiektów w innych publikacjach drukowanych lub elektronicznych jest dozwolone wyłącznie po uzyskaniu naszej pisemnej zgody i podaniu źródła.

3. OWH

Wyraźnie podkreślamy, że wszelkie dostawy odbywają się wyłącznie w oparciu o nasze Ogólne warunki sprzedaży i dostaw. Aktualna wersja naszych Ogólnych warunków sprzedaży i dostaw jest dostępna na stronie internetowej: www.elring.de/agb_de. Na żądanie możemy je także przesłać.

4. Inne

Nazwy, opisy, numery pojazdów i producentów itp. są przeznaczone wyłącznie do użytku wewnętrznego w celu porównania. To samo dotyczy oryginalnych numerów części zamiennych producentów pojazdów i silników. Nie stanowią one definicji pochodzenia i nie można ich stosować w odniesieniu do właścicieli pojazdów. Wraz z publikacją niniejszego katalogu tracą ważność wydania wcześniejsze.



We are not liable for printing errors. Keine Gewähr bei Druckfehlern. Toute garantie exclue pour les fautes d'impression. Se declina toda responsabilidad por erratas de imprenta. Si declina ogni responsabilità per eventuali errori di stampa. Zastrzegamy sobie prawo do błędów w druku.

ElringKlinger AG | Aftermarket Division
Max-Eyth-Straße 2 | 72581 Dettingen/Erms | Germany
Phone +49 7123 724-799 | Fax +49 7123 724-798
service@elring.com | www.elring.com

C5.10398.1024.EN.DE.FR.ES.IT.PL

